



DGS ERIS-230

Fixed gas detector

Designed for measurement of explosive hydrocarbon gases, toxic gases or oxygen in the ambient atmosphere

Operation manual



EAC

Content

Introduction.....	4
1 Safety precautions.....	5
2 Gas detector application.....	6
3 Manufacturer warranty.....	7
4 Gas detector design.....	8
4.1 External view.....	8
4.2 Overall dimensions.....	9
4.3 Gas detector design.....	10
4.4 Description of the front panel.....	11
4.5 OLED display description of DGS ERIS-230-3.....	13
5 Scope of supply.....	14
6 Storage and transportation.....	17
6.1 Storage of gas detectors.....	17
6.2 Transportation of the gas detectors.....	17
7 Marking and sealing.....	18
8 Technical specifications.....	19
8.1 Operation conditions.....	19
8.2 Design performance.....	19
8.3 Electrical specifications.....	19
8.4 Metrological performance.....	20
8.5 Reliability performance.....	21
8.6 Default configuration.....	21
9 Interface.....	22
10 Pre-starting procedure.....	23
11.1 Recommendations on optimal positioning of the gas detector.....	24
11.2 Wall (plate) mounting of the gas detector.....	24
11.3 Pipe mounting of the gas detector.....	25
11.3 Air duct mounting of the gas detector.....	26
11.5 Installation of the protective shield of the gas detector.....	27
12 Gas detector connection.....	29
12.1 Cables connection.....	29
12.2 Calculation of cable line length.....	32
12.3 Grounding procedure.....	33
13 First time switch-on (commissioning).....	35
13.1 Check of power supply connection.....	35
13.2 Installation inspection.....	37
14 Indication and operability check.....	38

14.1 Indication check.....	38
14.2 Relay activation test	41
15 Gas detector operation	42
15.1 Operation mode structure.....	42
15.2 The main menu of gas detector DGS ERIS 230-3.....	43
15.2.1 INFO menu.....	44
15.2.2 CALIBRATION menu	44
15.2.3 SETTINGS menu	45
15.2.4 TESTING menu.....	49
16 Zero calibration and span calibration.....	50
16.1 Zero calibration using the magnetic wand	51
16.2 Span calibration using the magnetic wand	52
16.3 Zero calibration by means of DGS ERIS-230-3 menu.....	54
16.4 Span calibration by means of DGS ERIS-230-3 menu.....	56
16.5 Zero calibration using HART communicator	58
16.6 Span calibration using HART communicator	60
16.7 Zero calibration using PC with installed software*	63
16.8 Span calibration using PC with installed software*	66
17 Possible faults	69
18 Maintenance	70
18.1 General guidelines	70
18.2 Visual inspection	71
18.3 Periodic operability check.....	71
18.4 Cleaning of sintered metal filter (for gas detector DGS ERIS-230IR)	71
18.5 Sensor replacement	72
18.6 Verification.....	72
19 Description and application of the audible and visible alarm	73
20 HART menu.....	77
21 RS485 communication protocol.....	79
22 Nominal static conversion function	84
Annex A Gases detected by flammable gas sensors (IR/CT).....	85
Revision record sheet.....	87

Introduction

The present operation manual is intended for study of structure, design and operating principle of the fixed gas detector DGS ERIS-230 (hereinafter referred to as DGS ERIS-230, gas detector, detector). The operation manual contains basic specification data, usage information, maintenance recommendations and other data required for proper operation, repair and storage of the gas detector.

The gas detector is admitted for use in the Russian Federation and has the pattern approval certificate issued by Federal Agency on Technical Regulating and Metrology RU.C.31.005.A № 59201 and is listed in State Register of Measuring Instruments of the Russian Federation under No. 61055-15.

The gas detector meets requirements of Customs Union Technical Regulation TR TS 012/2011 "The safety of equipment for explosive environments", conformity certificate No. TS RU S-RU.GB08.V.01361. Validity period: till 25.10.2020 inclusively.

The gas detector meets requirements of Customs Union Technical Regulation TR TS 020/2011 "Electromagnetic compatibility of technical equipment", registration number of conformity declaration of Eurasian Economic Union No. RU D-RU.AL16.V.64361. Validity period: till 23.01.2022 inclusively.

The gas detector meets requirements of Russian Maritime Register of Shipping, registration No.17.19075.130. Validity period: till 07.04.2022 inclusively.

The gas detector meets requirements of GOST 30546.1-98, GOST 30546.2-98, GOST 30546.3-98 (seismic resistance 9 on MSK-64 scale) conformity certificate No. ROSS RU.AV28.N21437. Validity period: till 02.06.2019 inclusively.

The gas detector meets requirements of 2014/30/EU Electromagnetic compatibility EN 61326-1:2013, conformity certificate No. 171199020. Validity period: till 12.02.2020 inclusively.

1 Safety precautions

The present operation manual shall be carefully studied before installation, operation and maintenance of the equipment. Special attention shall be paid to warning signs:



ATTENTION. Reference to the potential hazardous situation that in case of non-observance of the corresponding preventive measures could lead to personnel injury, device damage or environment incidents. Warning on device mishandling.



INFORMATION. Additional information on device handling.

The gas detector shall be operated only by personnel acquainted with the present operation manual and completed the safety training.

Do not operate the gas detector with mechanical damages of the housing or damaged seal.

Do not open the gas detector in an explosion hazard area when power supply is on.

Only trained personnel could have access to the internal parts of the gas detector for any works performance.

Installation and operation procedures shall correspond to rules and guidelines of "Electrical Installations Code" (EIC) and "Safety rules in Gas Industry".

Installation and connection of the gas detector shall be carried out with power off.

Connection of power-supply and interface circuits to the gas detector shall be performed in accordance with Section 12. In this case voltage shall not exceed the following U_m values:

for power-supply circuits $U_m=32$ V;

for interface circuits RS-485 MODBUS $U_m=6$ V.

The gas detector housing shall be grounded. Internal and external grounding devices with earth signs according to GOST 21130-75 are available for gas detector ground connection.

Repair of the gas detector shall be carried out by the manufacturer personnel or persons authorised by the manufacturer for repair works performance.

Do not disassemble detectors and interchange detectors parts.

Do not expose the detector to temperatures out of the specified operation range.

Do not expose the detector in storage to organic solvents or highly inflammable liquids.

Upon service life expiration the replaceable electrochemical oxygen and toxic gases sensors shall be environmentally friendly disposed. Disposal shall be carried out in accordance with the local regulations on waste management and legislation on environmental protection.

Do not discharge state standard sample of calibration gas mixture in the atmosphere of working premises during gas detector adjustment and verification.

2 Gas detector application

The gas detector DGS ERIS-230 is designed for measurement and information transfer on content of flammable gases and vapours of inflammable liquids (including petroleum vapours), toxic gases and oxygen in air of working area, process gas environment, industrial premises and open spaces of production facilities, pipelines and air ducts and for warning alarm on excess of the set alarm limit values.

The gas detector meets requirements of GOST 12.2.007.0-75, GOST 13320-81, GOST 27540-87, GOST 26.011-80, GOST R 52931-2008.

The gas detector is designed for fixed installation.

The gas detector is designed in accordance with TU 4215-020-56795556-2009.

Application field - explosion hazard areas according to 1Exd[ia]IICT6 X explosion proof mark where explosive mixture of gases and vapours could be generated.

The gas detector DGS ERIS-230 is produced in two modifications:

- DGS ERIS-230-1 is equipped with visual alarm circle, Status LED on the bottom of the front panel and four digit seven segment indicator;
- DGS ERIS-230-3 is equipped with three alarm LEDs, Status LED and OLED graphic display.

The sensor used in the gas detector:

- DGS ERIS-230IR – infrared sensor;
- DGS ERIS-230CT – thermocatalytic sensor;
- DGS ERIS-230EC – electrochemical sensor.

Sampling method is diffusion.

Working position of the gas detector is vertical, with the sensor downwards.

Operation mode is continuous.

Controlled medium is air of working area according to GOST12.1.005-88 and gas environment of production processes.

The gas detector shall be verified according to MP 116-221-2014 with amendment No.1. Verification intervals:

- DGS ERIS-230IR – 3 years;
- DGS ERIS-230CT, DGS ERIS-230EC– 1 year

3 Manufacturer warranty

Warranty period is 36 months from the sale date.

Warranty for the sensor:

- for DGS ERIS-230IR – 36 months;
- for DGS ERIS-230CT, DGS ERIS-230EC– 12 months.

The manufacturer warrants the device against defective parts. Warranty is not provided in case of non-observance of operation and storage conditions. Financial responsibility of the manufacturer shall not exceed under any circumstances the real cost paid by the buyer.

The warranty does not cover:

- fuses, batteries, filters and parts broken down as a result of normal wear during operation;
- any damages or defects resulted from improper installation and commissioning, repair of the device by persons non-authorized for repair and companies non-authorized by the manufacturer as service centres;
- defects resulted from force majeure circumstances (effects of acts of God, fires, floods, high-voltage discharges, lightings), injury, deliberate and incautious acts of the consumer or third parties.

4 Gas detector design

4.1 External view

Depending on housing materials gas detectors are divided into:

- the gas detector in aluminium housing;
- the gas detector in stainless steel housing.

Overall view of the gas detector is presented at Figures 1 and 2.



Figure 1 – External view of DGS ERIS-230-1, from left to right: in aluminium housing, in stainless steel housing



Figure 2 – External view of DGS ERIS-230-3, from left to right: in aluminium housing, in stainless steel housing

4.2 Overall dimensions

Overall dimensions of the gas detector are presented at Figures 3 and 4. All dimensions are indicated in mm.

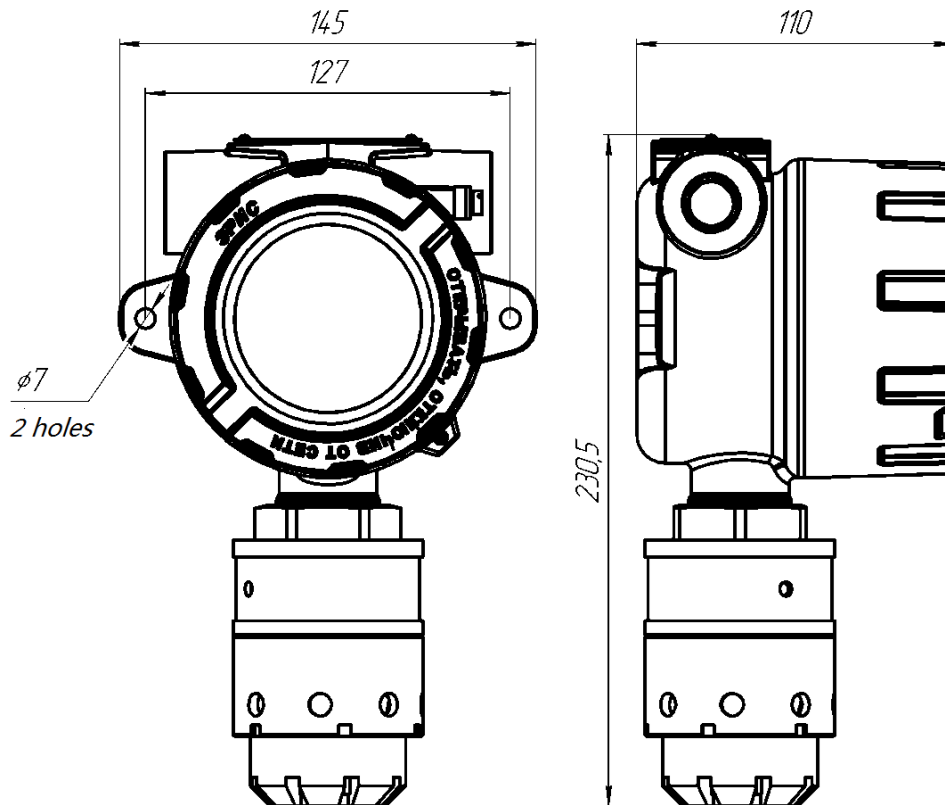

Figure 3 – Overall dimensions of DGS ERIS-230

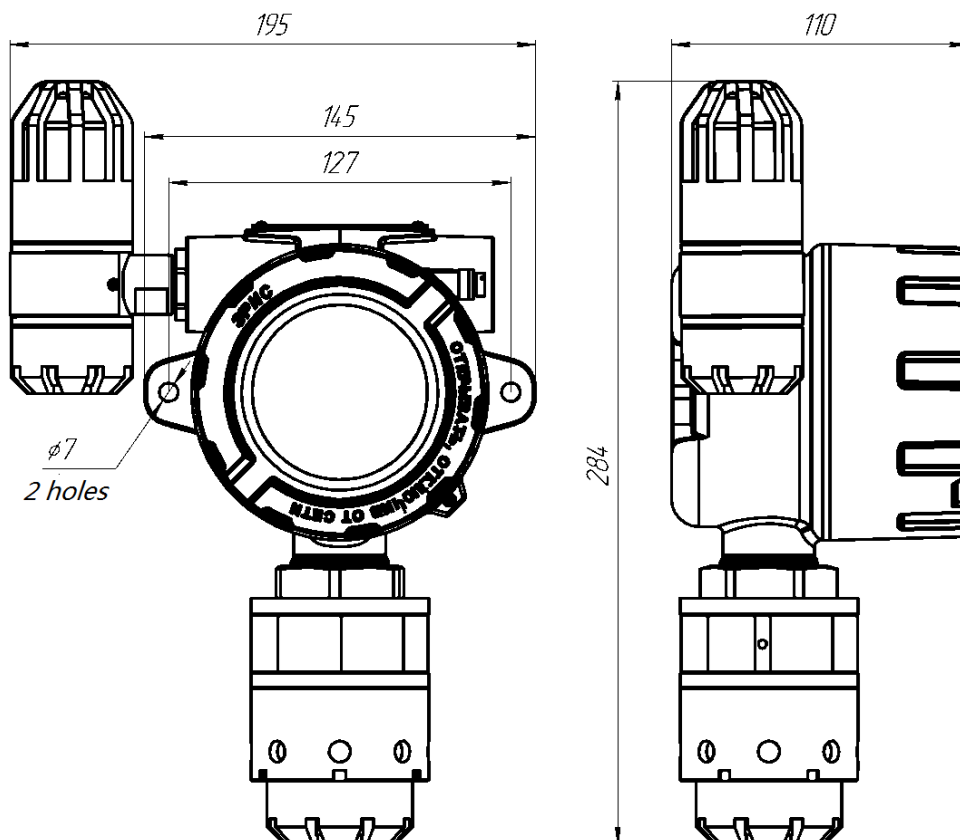

Figure 4 – Overall dimensions of DGS ERIS-230 with audible and visible alarm

4.3 Gas detector design

The gas detector is designed as the metal housing with the cover. The gas detector housing has three threaded entries. Two cable / electric conduits entries located on the both sides of the upper part of the gas detector housing are intended for connection of power supply source, signal output, relay contacts, and HART connector or audible and visible alarm (Figure 5). The bottom entry ensures direct connection of the measurement module. The gas detector housing has the integral mounting plate providing the use of various mounting options. The gas detector cover has a glass window which allows to monitor the device status by means of LED and digital indication and to use the magnetic wand for activation of three magnetic switches located on the front panel of the electronic module (Picture 5). The magnetic wand also enables a non-intrusive one-man adjustment of the gas detector.

The lock screw is used to prevent the cover unscrewing. To unscrew the lock screw the hexagon wrench supplied along with the gas detector is used.

The gas detector consists of the following functional components (Figure 5):

- measurement module;
- terminal module;
- electronic module;
- housing and cover.

The measurement module is equipped with the sensor (infrared, thermocatalytic or electrochemical). The sensor function is to detect the specific gas, transform the gas concentration into the digital signal and transmit the signal to the electronic module. The sensor of the gas detector DGS ERIS-230IR is protected by the metal ceramic filter integrated into the sensor cover. The measurement module is equipped with the moisture protection cap for protection against moisture.

The terminal module is designed for digital signal transmission from the measurement module to the electronic module for connection of the external power-supply circuits, analog and digital outputs, arrangement and connection of relay outputs.

The electronic module is equipped with the intrinsic safety barrier to ensure intrinsically safe circuits. To intrinsically safe circuits belong series of circuits between measurement and electronic modules. Therefore such circuits do not restrict the external connections and do not require the use of external intrinsic safety barriers to ensure explosion protection of the gas detector. Main functions of this module: generation of analog and digital signals and signals transmission to the terminal module, operation status indication of the gas detector. This module is equipped with magnetic switches for the gas detector calibration.

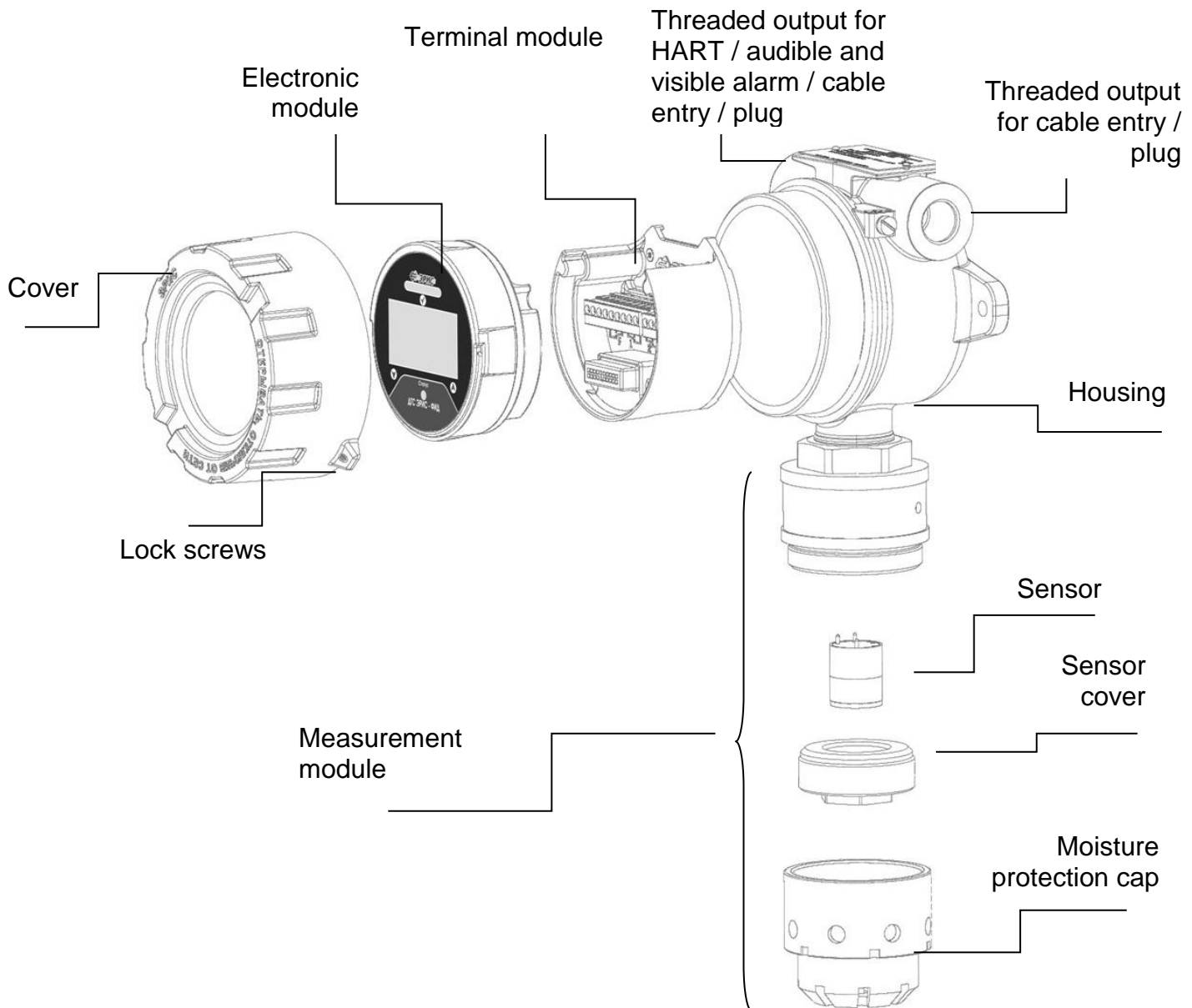

Figure 5 – Functional structure of DGS ERIS-230

4.4 Description of the front panel

The front panel of the gas detector includes (Figure 6, Figure 7):

- Status condition LED,
- magnetic switch areas UP/DOWN/ENTER for local adjustment,
- alarm LED circle of DGS ERIS-230-1,
- four digit LED indicator of DGS ERIS-230-1,
- alarm three LEDs of DGS ERIS-230-3,
- OLED display of DGS ERIS-230-3.

Status LED glows GREEN during normal operation of the device.
LED blinks RED in case gas concentration exceeds upper or lower alarm limits. Operation statuses of the gas detector are described more detailed in clause 14.1, Table 5 or Table 6.

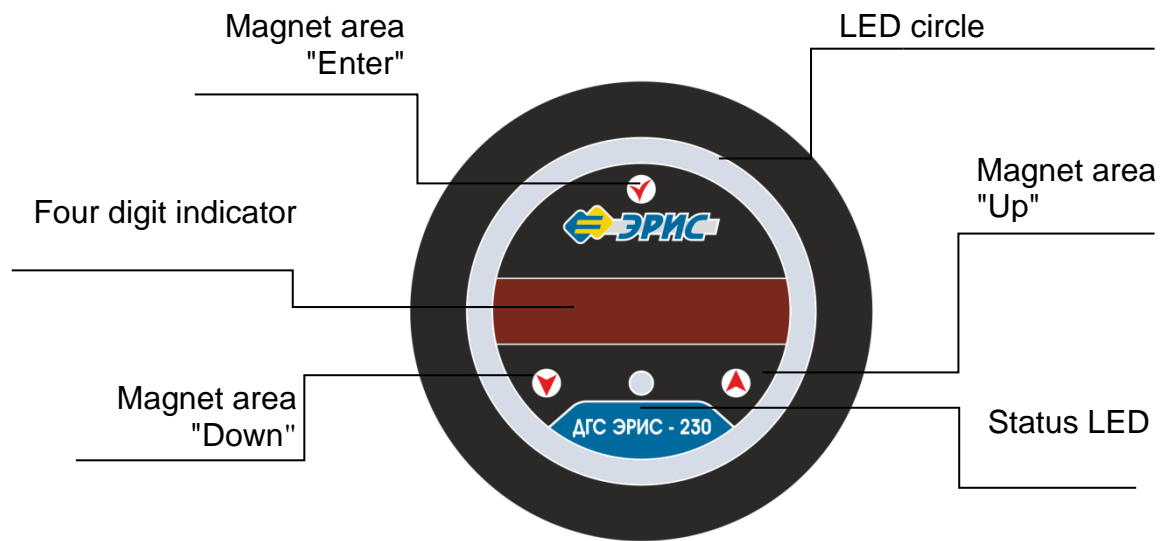

Figure 6 – Front panel of DGS ERIS-230-1

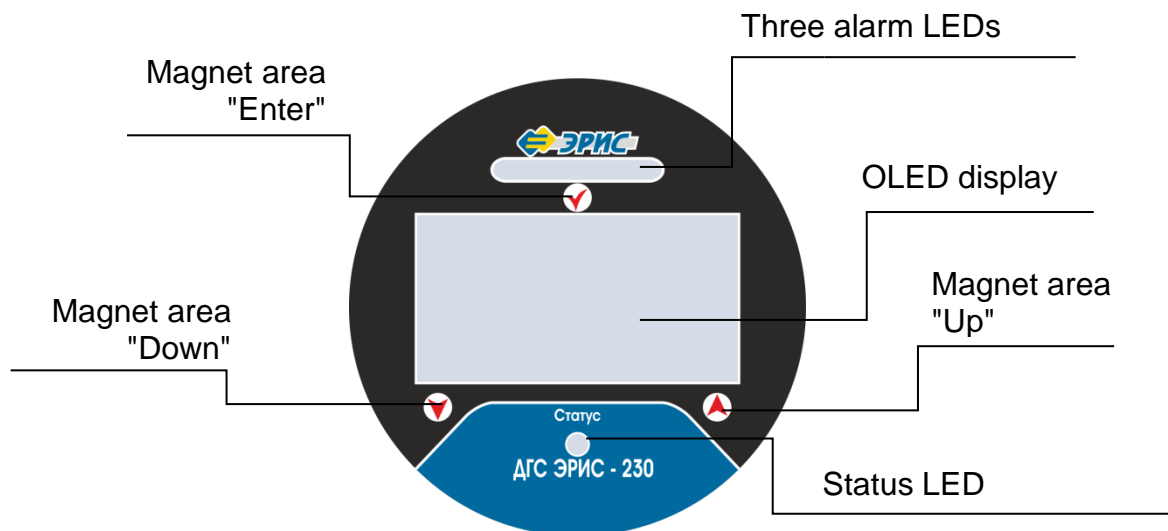
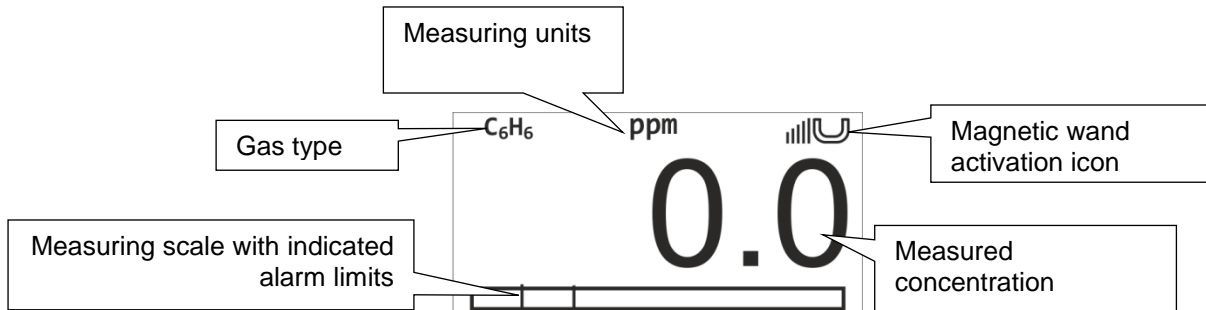



Figure 7 – Front panel of DGS ERIS-230-3

4.5 OLED display description of DGS ERIS-230-3



OLED display of DGS ERIS-230-3 provides information on gas type, gas concentration, measuring units and measuring scale with indicated alarm limits. The display provides numerical, bar graph and icon information.

Icon information is also displayed when the magnetic wand is used during the gas detector operation.

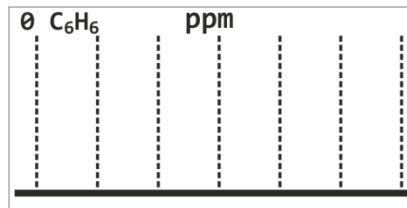

By positioning of the magnetic wand near the icon  (on the front panel of the gas detector) the diagram indicating the measured concentration during previous detector operation is displayed. Diagram movement interval is set in the menu (Menu>>Settings>>Interfaces >>Display). Position the magnetic wand near the same icon or icon  to return to the measuring mode.



By positioning of the magnetic wand near the icon  the current information on detector is displayed. Position the magnetic wand near the same icon or icon  to return to the measuring mode.

0.0 C ₆ H ₆ ppm		0.0 C ₆ H ₆ ppm	
U _{sup} , V. :	23.0	DETEC. SER .N°:	ER0
MEAS. RANGE :	0.5/50.0	HW VER. :	v.0.00.00
ALARM 1:	5.0	SW VER. :	v.1.06.086
ALARM 2:	10.0	SENS. SER .N°:	171171
I _{out} , mA:	4.16	HW VER. :	v.0.00.00
		SW VER. :	v.2.04.226

5 Scope of supply

Scope of supply of gas detectors DGS ERIS-230:

Designation	Quantity, pcs.
Gas detector DGS ERIS-230	1
Certificate	1
Operation manual	1*
Verification procedure MP 116-221-2014 with revision No.1	1*
Hexagon wrench	1
Conformity certificate TR TS	1*
Packing	1
Software	1**
Magnetic wand (see below)	1
Moisture protection cap	1

Note:

* One copy for 10 gas detectors in lot, but minimum one copy for shipment.

** Available on the website free of charge: www.eriskip.com

Additional accessories for DGS ERIS-230:

① Magnetic wand.

Magnetic wand is used for the gas detector calibration.

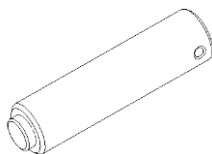

② Calibration cap***.

Calibration cap is used for span calibration of the gas detector by gas mixture. It is used for periodic operability check as well.

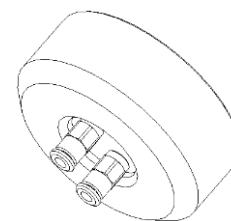

③ Pipe mounting kit***. The gas detector can be mounted on pipe with diameter 38...68 mm.

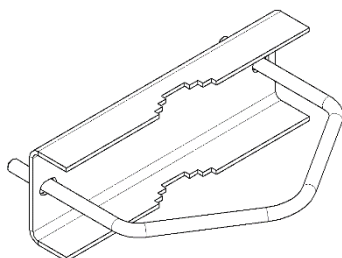

④ Shield for protection against atmosphere precipitation and sun***. The shield is used for protection of the gas detector installed outdoors against overheating in warm season or against heavy atmosphere precipitation in winter time.

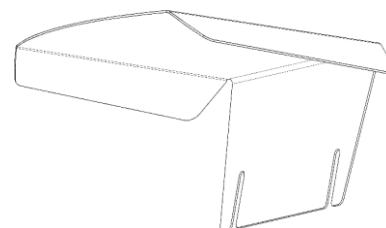

⑤ Cable entry*.**

It ensures easy and safe entry of the cable to the housing of the gas detector. Specific type of the cable entry shall be specified at the time of order. Mounting torque is 40Nm.

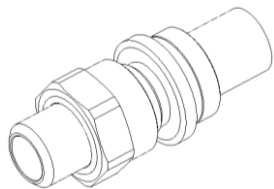
**⑥ Plug***.**

The plug shall be screwed in the cable entry port. Mounting torque is 40Nm.

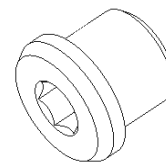
**⑦ Audible and visible alarm***.**

Audible and visible alarm is used for additional status notification of the gas detector. Mounting torque is 50Nm.

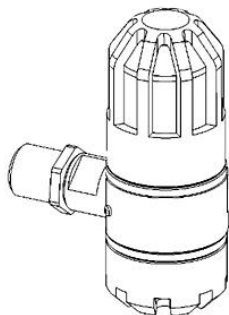
**⑧ HART communicator connection device***.**

Additional HART connector is used for information output via HART to communicator. Mounting torque is 40Nm.

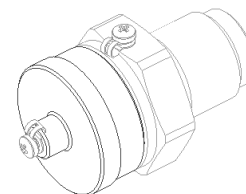

⑨ Flow nozzle for process environment***.

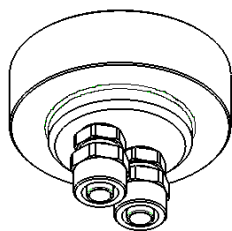

⑩ Air duct mounting kit***.

It is used in case gas monitoring inside air ducts is required. Installation of this kit shall be carried out in accordance with clause 11.4.

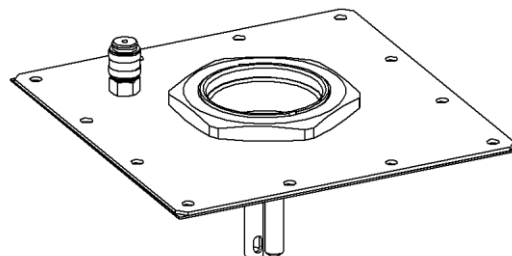

*Note - *** Supplied optionally*



Audible and visible alarm and HART communicator connection device could not be used simultaneously.

6 Storage and transportation

6.1 Storage of gas detectors

The gas detector and operational documentation are packed in carton box. Packing method, preparation for packaging, transport package and materials used during packaging, positioning order correspond to the manufacturer drawing.

Gas detectors shall be stored at supplier and consumer stock in original package under conditions No.1 according to GOST 15150-69 (heated warehouses and storehouses with air temperature from plus 5 to plus 40 °C)*. Gas detectors shall be placed on racks during storage.



Gas detectors could be stored at negative temperatures down to 20°C provided that ports of cable entries are plugged. *The gas detector shall stay switched off in normal conditions minimum 12 hours before installation and switch-on.*



Zero calibration and span calibration of the gas detector (Section 16) shall be carried out during commissioning in case the gas detector was stored more than 12 months.

After unpacking the gas detector storage conditions shall be equal to the mentioned above.

Storage environment shall not contain harmful impurities causing corrosion.

Distance between heating units of storehouses and gas detectors shall be minimum 0.5 m.

6.2 Transportation of the gas detectors

Transportation conditions are under storage conditions 5(OZh4) according to GOST 15150-69. Temperature range is from minus 60 to plus 65°C.

Transportation of gas detectors shall be carried out by air, by rail, by water and by road in closed vehicles, heated pressurized compartments of planes in accordance with regulations concerning goods transportation valid for the corresponding means of transport.

Packed gas detectors shall not be subjected to sharp impacts and exposure to atmospheric precipitation during loading and unloading operations and transportation.

7 Marking and sealing

The gas detector marking includes the following information:

- manufacturer name and trade mark;
- gas detector type;
- molecular formula of the measured gas;
- measurement range;
- year of manufacture;
- serial number of the gas detector under manufacturer numbering system;
- pattern approval mark according to PR 50.2.009;
- explosion protection designation;
- explosion safety sign in accordance with TR TS 012/2011;
- warning notice "Open only after mains disconnection";
- ingress protection rating of IP67;
- operation temperature;
- certificate number;
- grounding sign.



Sealing of units are used for protection against unauthorized access to the internal parts of the gas detector (Picture 8): electronic module, measurement module, terminal module, HART connector or audible and visible alarm. Secure seals are executed as damageable labels.



Gas detector without cover and electronic module.

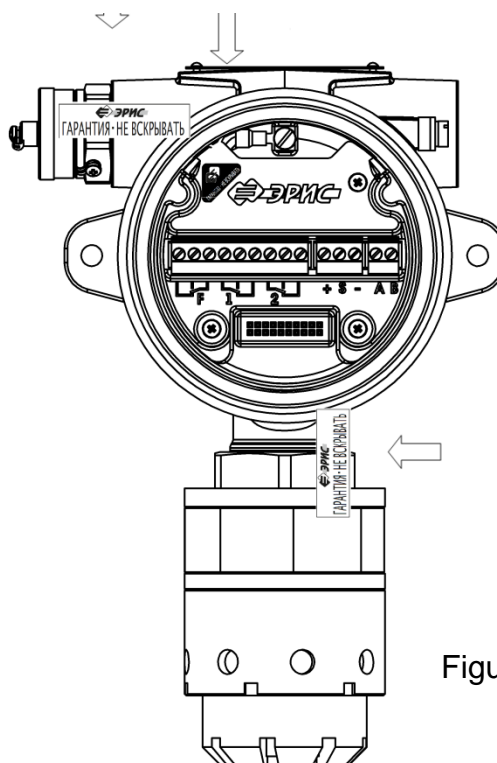

Back view of the electronic module.

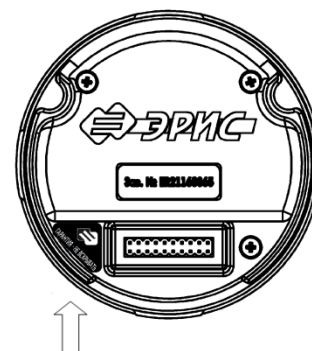

Figure 8 - Sealing allocation

8 Technical specifications

8.1 Operation conditions

The gas detector is designed for operation in the following environmental conditions:

- ambient temperature range - from -60 up to $+60^{\circ}\text{C}$;
- relative humidity - no more than 98 %;
- atmospheric pressure - from 84 up to 106.7 kPa;
- content of mechanical and aggressive impurities in the controlled medium shall not exceed maximum permissible concentration limits according to GOST 12.1.005-88.

DGS ERIS-230 gas detectors correspond to D3 design according to GOST R 52931-2008 in respect of resistance to influence of ambient air temperature and humidity.

The gas detector is proof against vibration in frequency range from 10 to 30 Hz with total displacement for 1 mm and in frequency range from 31 to 150 Hz with acceleration amplitude $19,6 \text{ m/s}^2$ (2g) according to GOST R 52931-2008.

The gas detector is proof against radio-frequency electromagnetic field in the range from 80 to 1000 MHz (emission from common sources) and in the range from 800 to 960 MHz and from 1.4 to 6.0 GHz (emission from digital wireless phones and other radio frequency devices) according to GOST R 51317.4.3-99, electromagnetic field strength is up to 3 V/m.

8.2 Design performance

Explosion protection type and level of the gas detector corresponds to 1Exd[ia]IICT6X.

Level of human protection against electric shock of the gas detector corresponds to III class according to GOST 12.2.007.0-75.

Level of protection against water, dust and other solid particles penetration into the gas detector corresponds to IP67 code according to GOST 14254-96 (MEK 529-89).

Overall dimensions of the gas detector (without audible and visible alarm), maximum: $150 \times 110 \times 235 \text{ mm}$. Overall dimensions of the gas detector (with audible and visible alarm), maximum: $195 \times 110 \times 284 \text{ mm}$.

Gas detector weight:

- maximum 2.0 kg in aluminium housing;
- maximum 3.9 kg in stainless steel housing;
- with audible and visible alarm - additional 0.35 kg.

8.3 Electrical specifications

Power supply voltage of the gas detector: 13-36 V DC.

Gas detector power consumption depending on the operation mode:

- switch-on – maximum 6.3 W;
- warming-up – maximum 1 W;
- measuring mode – maximum 1.3 W;
- measuring mode when alarm is active (alarm limit is exceeded) - maximum 2.2 W;

- sensor warming-up - additionally 3 W (automatic switch-on at ambient temperature +5°C and below. Only for DGS ERIS-230EC);
- operation of audible and visible alarm, in measuring mode – additionally 2.3 W;
- operation of audible and visible alarm when alarm is active (alarm limit is exceeded) - additionally 6.2 W.

Time limits of the gas detector warming-up:

- DGS ERIS-230IR – maximum 2 minutes;
- DGS ERIS-230CT, DGS ERIS-230EC – maximum 10 minutes.

Cable length from the gas detector to the controller depends on power supply voltage and selected cable. Length calculation is presented in clause 12.2.

Load impedance of current loop circuit is maximum 500 Ohm.

Maximum commutated current of relay - 2 A, 220 V AC (or 250 V DC).

8.4 Metrological performance

Measurements ranges of gases and limits of permissible reference error of DGS ERIS-230 are indicated in annex A. Gases detected by flammable gas sensors are indicated in annex B.

DGS ERIS-230EC gas detectors with electrochemical sensors could ensure measurement of volume and mass concentration of the gas. Recalculation of volume concentration values, ppm (or million⁻¹) to mass concentration, mg/m³ is carried out by the following formula:

$$C_{mg/m3} = \frac{M \cdot C_{ppm}}{R \cdot T/P},$$

where $C_{mg/m3}$ – gas concentration value, mg/m³;

C_{ppm} – gas concentration value, ppm;

M – molar mass of gas;

R – absolute gas constant, equal to 8,314472;

P – atmospheric pressure, kPa;

T – temperature, K.

Under normal conditions ($T = 293.15$ K, $P = 101.325$ kPa) the formula is written as:

$$C_{mg/m3} = C_{ppm} \cdot K,$$

where K - correction factor under normal conditions. Correction factors under normal conditions are indicated in the gas detector certificate.

Output signal variation in ratio of the reference error is not more than 0.5.

Permissible additional error associated with ambient temperature change for every 10 °C in ratio of the reference error is ±0.2.

Time of the input signal setting of the gas detector on level 0.9 ($T_{0.9}$):

- DGS ERIS-230IR – 5 seconds;
- DGS ERIS-230CT – 10 seconds;
- DGS ERIS-230EC – 15 seconds.

Time of the input signal setting depends on ambient temperature and measured gas.

Limit of the permissible interval of the gas detector operation period without output signal adjustment - minimum 6 months.

8.5 Reliability performance

Average time between failures of the gas detector:

- DGS ERIS-230IR – minimum 70000 hours;
- DGS ERIS-230CT, DGS ERIS-230EC – minimum 35000 hours.

Failure criterion - tolerance failure of reference error, functionality failure.

Average full service life of the gas detector is minimum 15 years.

8.6 Default configuration

DGS ERIS-230 is supplied calibrated and ready for use in accordance with default configuration described in Table 1.

Table 1- Default settings

Function	Value / Setting	Description
Detector type	Automatic selection depending on the connected sensor type.	DGS ERIS-230 recognizes the sensor in accordance with gas type within its own sensor family: sensors IR,CT,EC
Signal output	less than 1.5 mA	Fault
	from 4.0 mA to 20.0 mA	Normal measuring mode
	22.0 mA	Exceeding of the maximum permitted limit
ALARM Relay 1*	Contact normally opened (NO)	Closing in case alarm limit is exceeded
ALARM Relay 2*	Contact normally opened (NO)	Closing in case alarm limit is exceeded
Fault Relay	Contact normally closed (NC)	Opening in case of alarm.
Timeout period	2 minutes	Time of automatic exit from the service mode
Sensor warming up	Switch-on in case of ambient temperature is +5°C.	Automatic switch-on
ModBus	ID, baud rate and parity bit	ID: 1 Baud rate 9600 Parity bit No
Note - * Relays automatically reset when reading is within the range specified by the alarm thresholds.		

9 Interface

The gas detector ensures output of information on measured concentration value by the following interfaces:

- integrated four digit LED indicator (for DGS ERIS-230-1) or OLED display (for DGS ERIS-230-3);
- Status LED on the bottom of the front panel;
- 3 LEDs located at the top or 8 LEDs located circle-wise for visual alarm in case of alarm limits achievement or fault detection;
- audible and visible alarm (optionally). Audible and visible alarm is described in Section 19;
- digital serial interface RS-485 MODBUS® (communication protocol is described in Section 21);
- current loop 4-20 mA (nominal static conversion function is described in Section 22);
- 3 relays (Alarm 1, Alarm 2, Fault) (optionally);
- 3 relays (Alarm 1, Alarm 2, Alarm 3) (optionally only for gas detectors designed for ammonia concentration measurement);
- HART protocol (local or through the current loop) (optionally). Local HART is provided by the HART communicator connection device. HART protocol menu is described in Section 20.



Audible and visible alarm and HART communicator connection device could not be used simultaneously.

10 Pre-starting procedure



The gas detector shall be operated only by personnel acquainted with the present operation manual and completed the safety training.

Do not operate the gas detector with mechanical damages of the housing or damaged seal.

Only trained personnel could have access to the internal parts of the gas detector for any works performance.

After unpacking of the gas detector check scope of supply, seals, explosion proof markings, absence of mechanical damages.

In case the gas detector was kept in transport package at negative temperature, it should be kept switched off under normal conditions not less than 12 hours.

If cable entries are available, they shall be installed in the corresponding ports of the gas detector housing. Mounting torque of the cable entry is 40Nm.

11 Gas detector installation



The gas detector installation on site shall be carried out in accordance with the approved under the established procedure project of allocation of monitoring system with the gas detector.

During installation and operation the guidelines of the following documents shall be followed:

- *clause 7.3 of "Electrical Installations Code" (PUE);*
- *clause 3.4 of "Rules of operation of electric installations of consumers" (PEEP);*
- *"Safety Rules for Operation of Customers' Electrical Installations" (PTB).*

Gas detectors shall be grounded. The ground screw is located on the outside of the housing and marked accordingly .

11.1 Recommendations on optimal positioning of the gas detector

- The gas detector shall be positioned at place specified by the design documentation where gas could possibly be detected.
- For measurement of lighter-than-air gases the gas detector shall be positioned above the protected area. For measurement of heavier-than-air gases the gas detector shall be positioned below the protected area.
- The gas detector shall be positioned at places with sufficient air circulation. Limitation of the natural air flow could be the reason of the delayed response.
- Do not install the gas detector in direct sunlight without shield for protection against atmosphere precipitation and sun.
- Do not install the gas detector at places subjected to rain, water, aerosol sprays, fog or strong condensation, dust sources, vapours without shield for protection against atmosphere precipitation and sun.
- Do not install the gas detector near heat sources.
- The gas detector shall be installed at places providing maintenance access.

The gas detector is equipped with the built-in mounting plate with two mounting holes in the housing. The gas detector could be installed directly on the mounting surface (wall, plate) or at pipe with diameter 38-68 mm (1.5–2.7 inch) in vertical position or at air duct.

11.2 Wall (plate) mounting of the gas detector

Mounting dimensions for fastening shall be observed in accordance with Figure 9 in case of wall (plate) mounting of the gas detector. All dimensions are indicated in mm. Mounting shall be carried out by screws and nuts M6. View of the wall mounted gas detector is shown at Figure 10. Make sure that mounting screws are properly tightened and appropriate lock washers are used. During the mounting process make sure that the gas detector has access to the measured air and there is enough space for further dismounting and operability check.

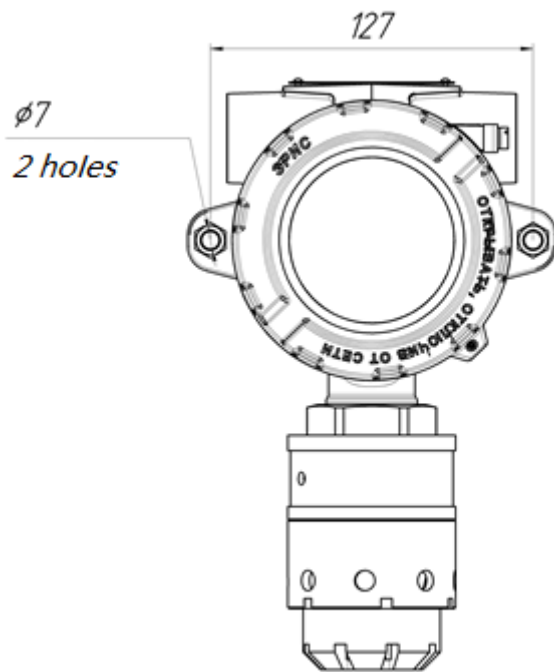

Figure 9 – Mounting dimensions

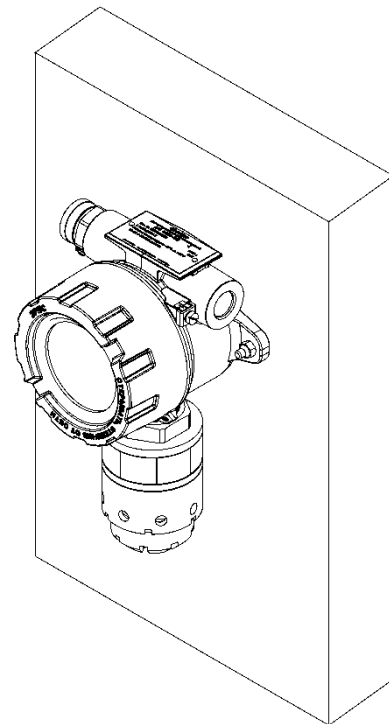

Figure 10 – View of the wall mounted gas detector

11.3 Pipe mounting of the gas detector

Pipe mounting kit (Figure 11) shall be used for pipe mounting of the gas detector (supplied optionally). The external view of the pipe mounted gas detector with installation kit is shown at Figure 12. Maximum diameter of the pipe for installation is 68 mm; minimum diameter is 38 mm. All dimensions are indicated in mm.

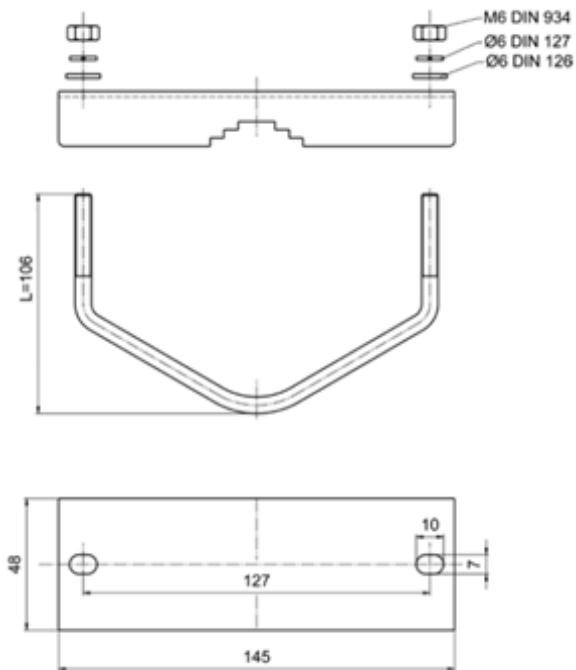

Figure 11 – View of the pipe mounting kit

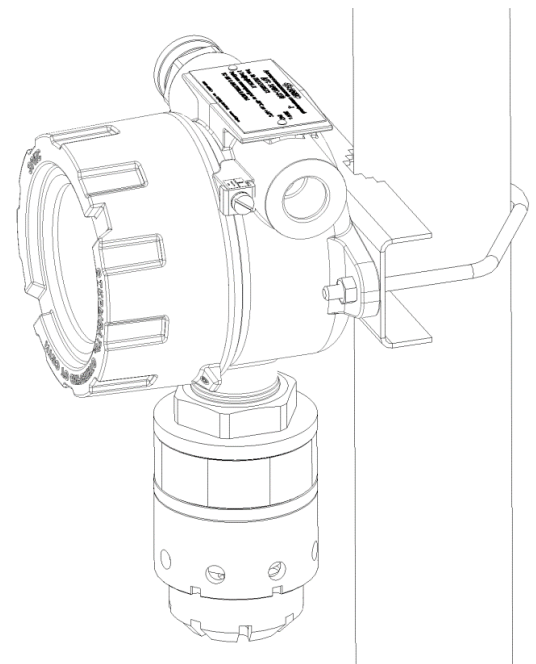

Figure 12 – View of the pipe mounted gas detector

11.3 Air duct mounting of the gas detector

Area on the upper wall of the air duct shall be prepared for installation of the air duct mounting kit (hereinafter referred to as the kit) (Figure 13.). Other mounting methods could be used providing tightness and resistance (for example, by self-driving screws). All dimensions are indicated in mm.

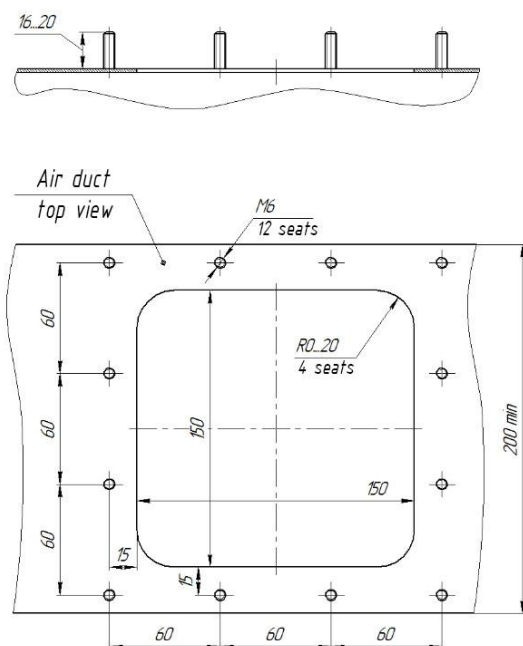

Figure 13 – Kit installation area

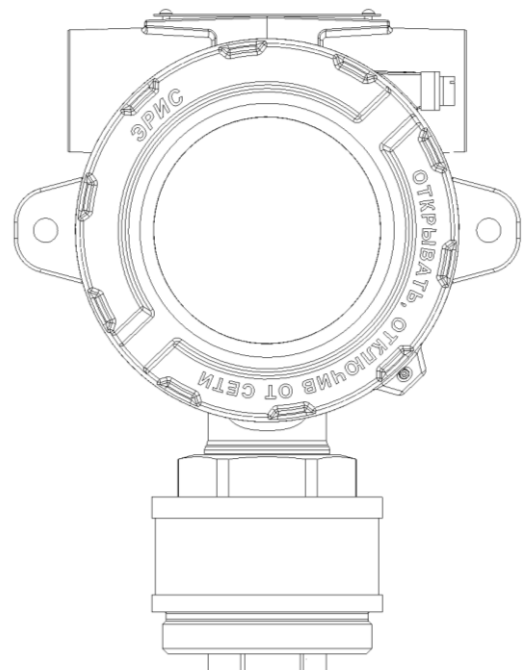

Figure 14 – Gas detector without moisture protection cap

Installation order of the air duct mounting kit and the gas detector:

- a) Position the kit on the prepared area at the air duct. Fix by nuts M6. Rubber seal shall be pressed between plate and air duct wall;
- b) Remove the moisture protection cap from the gas detector (Figure 14);
- c) Screw the gas detector into the cover of the kit (Figure 15);
- d) Further connection of the gas detector shall be carried out in accordance with clause 12.1.

External view of the mounted gas detector is shown at Figure 15.

The corresponding gas mixture shall be supplied to the gas feeding point by means of the quick release connector (supplied complete with) in order to check operability of the gas detector. Gas mixture flow rate is 0.5-0.6 l/min.



Disconnect the quick release connector after completion of operability check in order to avoid gas discharge outside from the air duct.

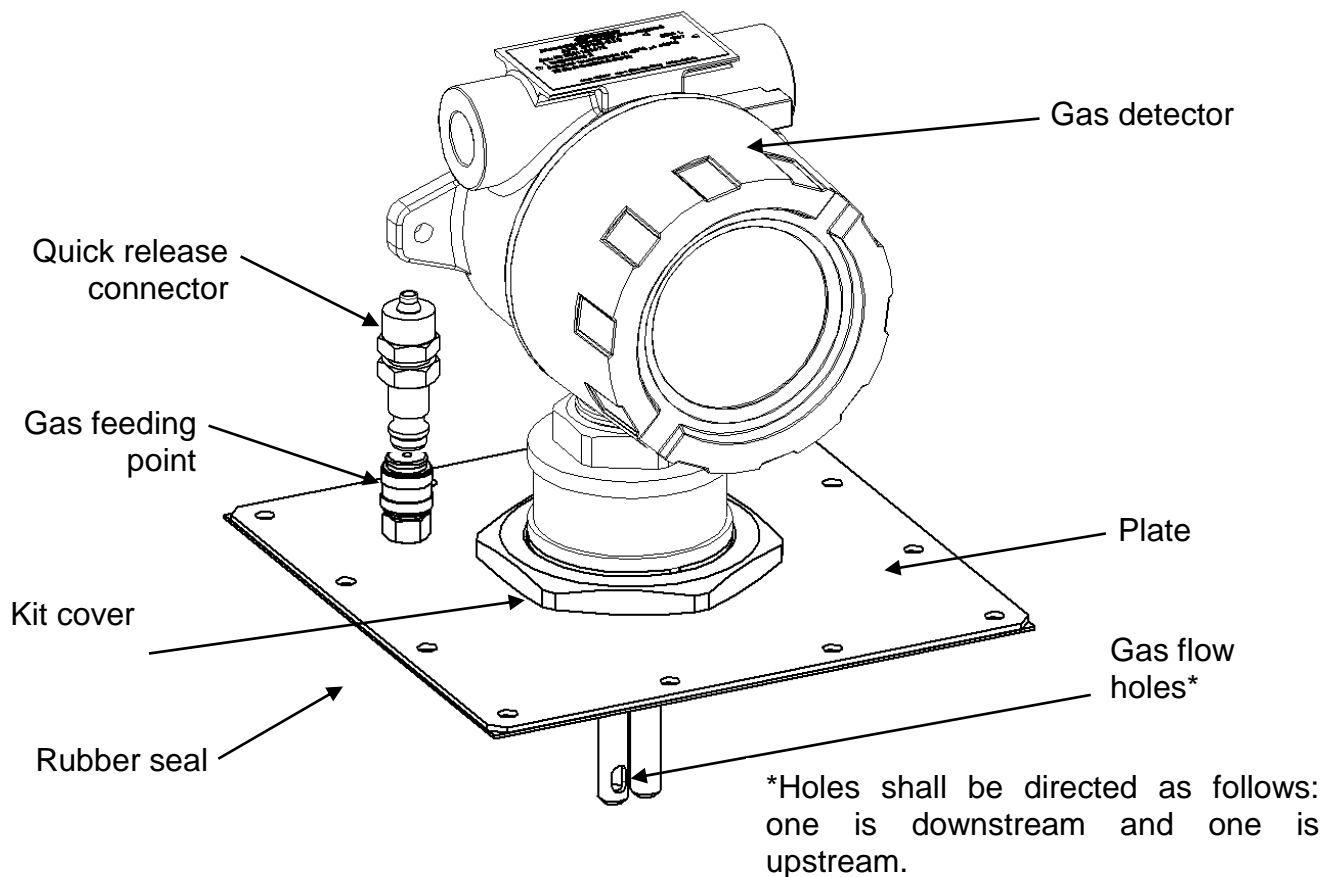

Figure 15 – External view of the gas detector and air duct mounting kit.

11.5 Installation of the protective shield of the gas detector

The external view of the gas detector with installed protective shield in case of pipe mounting is shown at Figure 16.

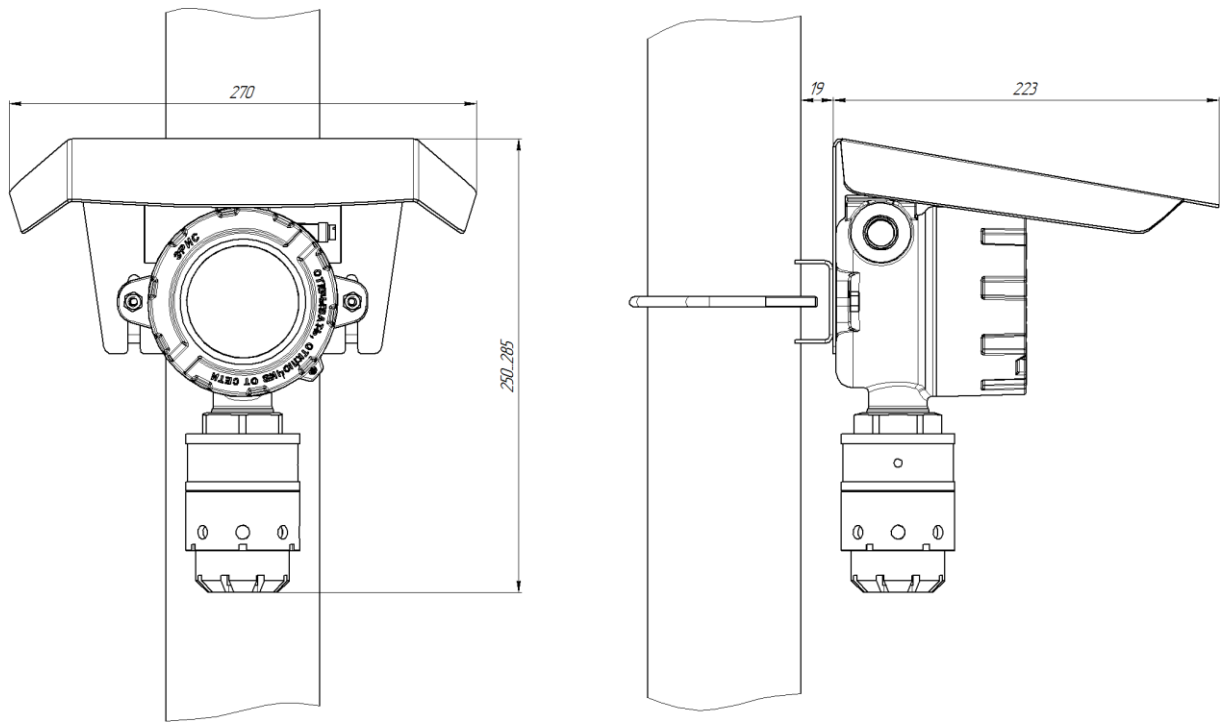

Figure 16- Mounting of the protective shield of the gas detector

12 Gas detector connection



The gas detector shall be operated only by personnel acquainted with the present operation manual and completed the safety training.

Only trained personnel could have access to the internal parts of the gas detector for any works performance.

Installation and operation procedures shall correspond to rules and guidelines of "Electrical Installations Code" (PUE) and "Safety rules in Gas Industry".

Installation and connection of the gas detector shall be carried out with power off.

Connection of power-supply and interface circuits to the gas detector shall be performed in accordance with Section 12. In this case voltage shall not exceed the following U_m values:

for power-supply circuits $U_m=32$ V;

for interface circuits RS-485 MODBUS $U_m=6$ V.

The gas detector housing shall be grounded. Internal and external grounding devices and earth signs according to GOST 21130-75 are available for gas detector ground connection.

Do not expose the detector to temperatures out of the specified operation range.

12.1 Cables connection

Cables connection inside the gas detector shall be carried out in the following order:

- a) Screw off lock screws in the gas detector cover (Figure 17).
- b) Screw off the cover.
- c) Remove the electronic module from connectors by pulling the semicircular handle.

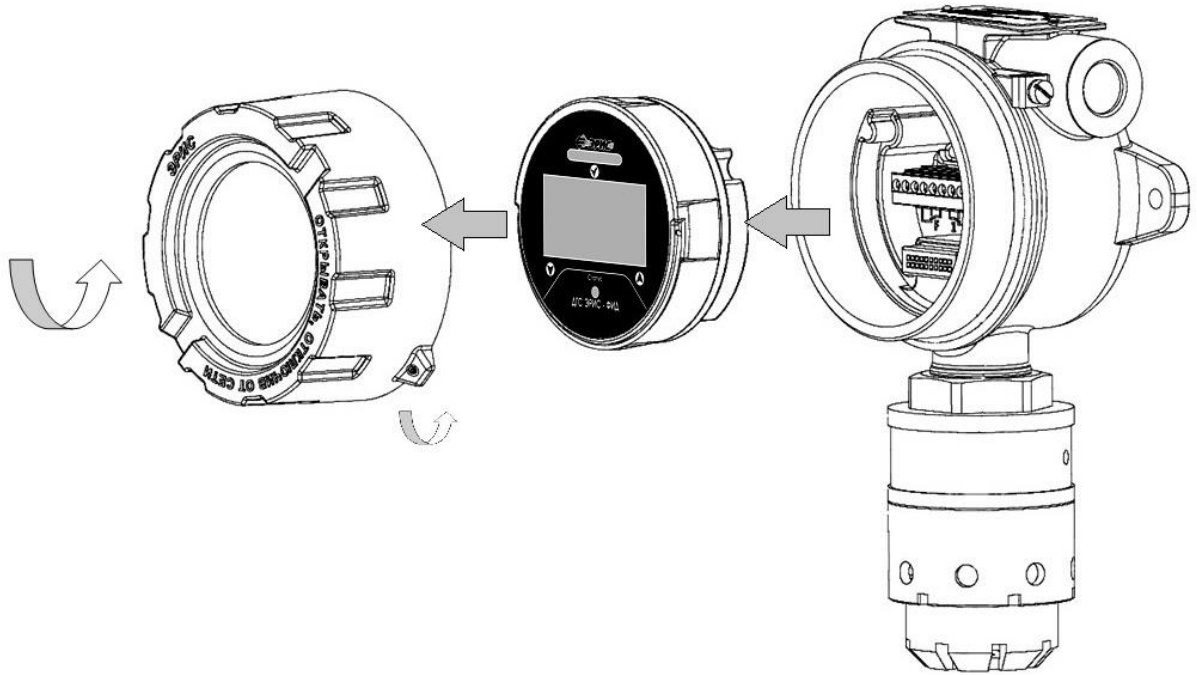

Figure 17– DGS ERIS-230 disassembling diagram

- d) Cables connection shall be carried out in accordance with application and marking on the terminal module (connection diagrams according to Figures 18-21).
- e) After connection the device shall be assembled in the in reverse order.

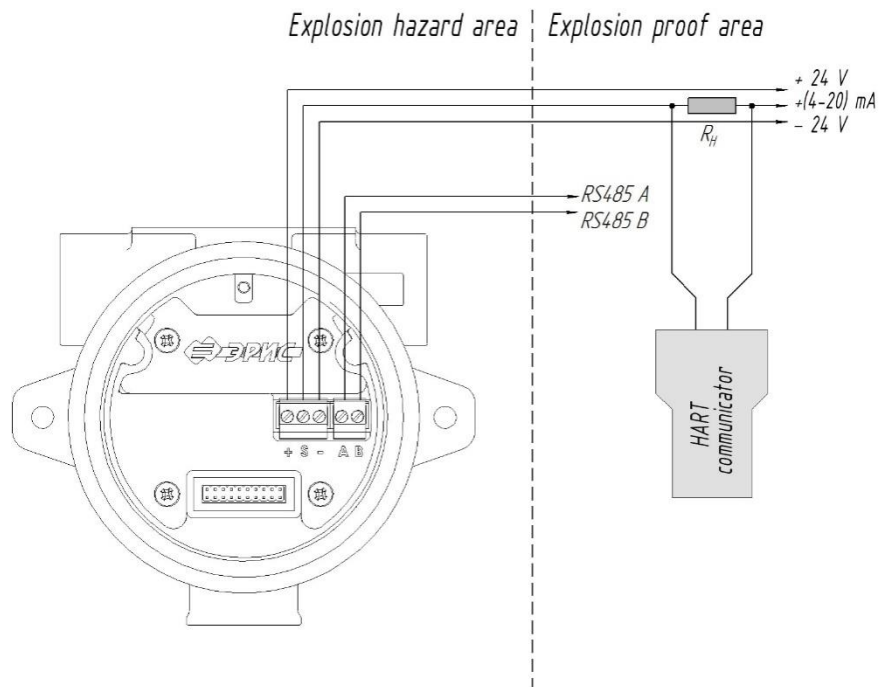

Figure 18 – 3-wire connection diagram of the gas detector DGS ERIS-230 without relay with HART connection using the current loop

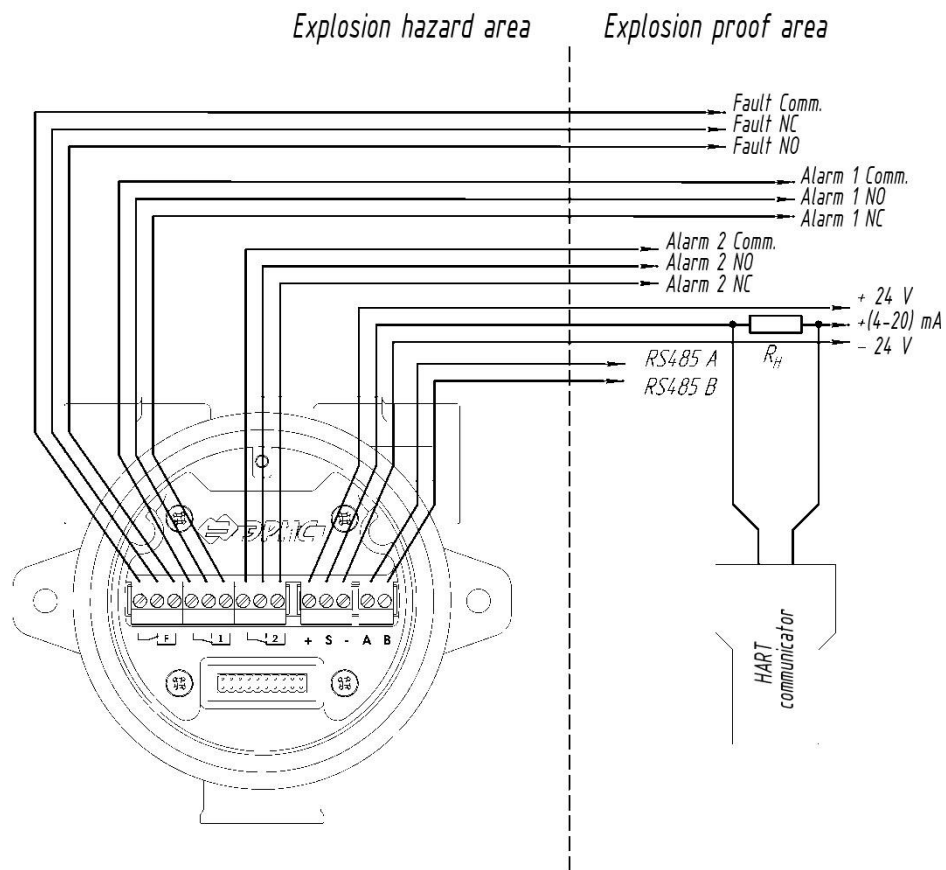

Figure 19 – 3-wire connection diagram of the gas detector DGS ERIS-230 with relay with HART connection using the current loop. NO - contact normally opened; NC - contact normally closed.

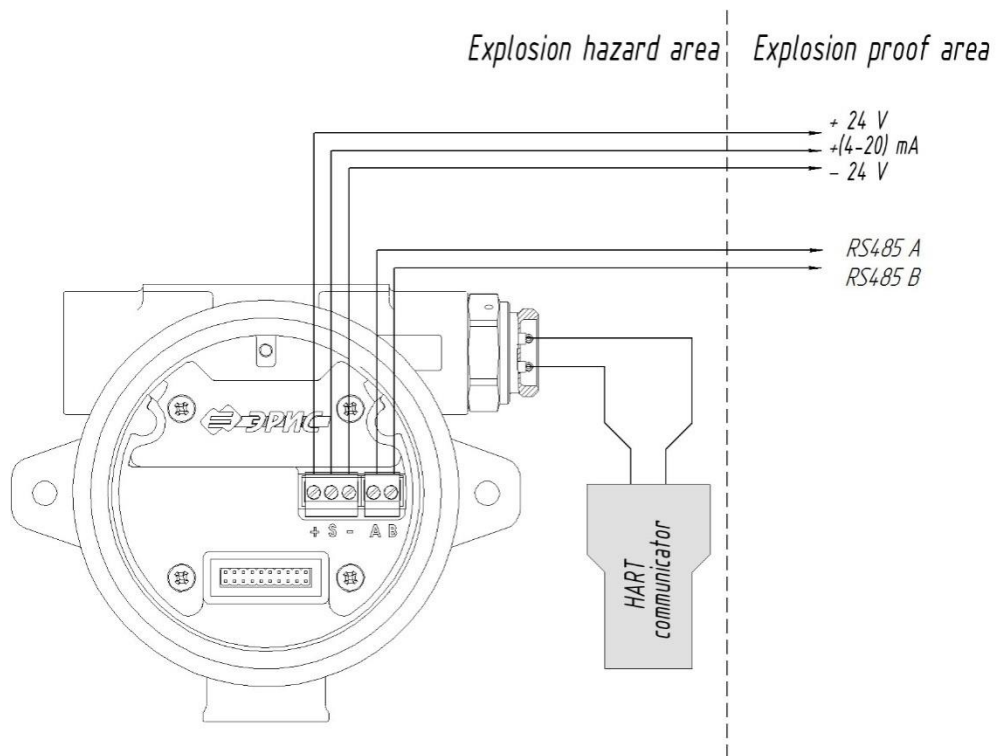

Figure 20 – 3-wire connection diagram of the gas detector DGS ERIS-230 without relay and with local HART connection

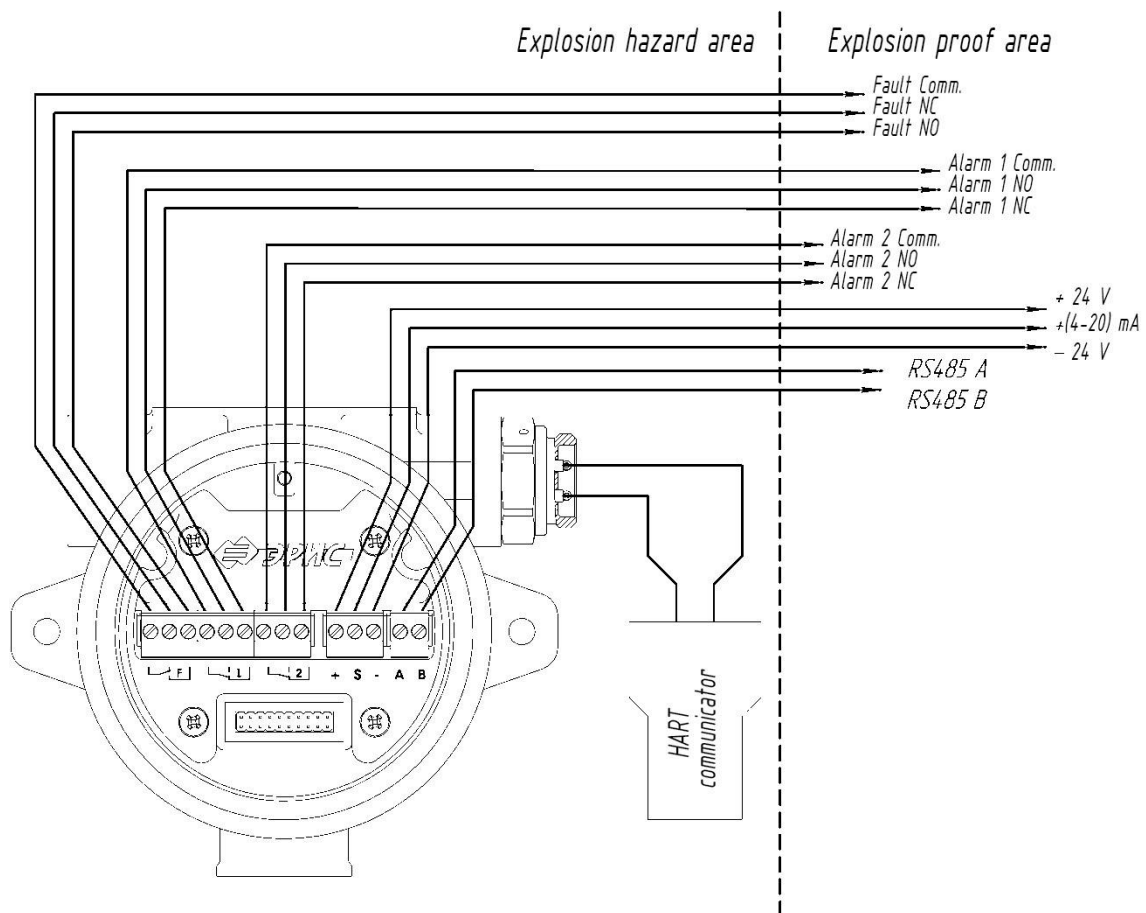

Figure 21 – 3-wire connection diagram of the gas detector DGS ERIS-230 with relay and with local HART connection. NO - contact normally opened; NC - contact normally closed.

12.2 Calculation of cable line length

To calculate maximum power cable line length of the detector the following needs to be defined:

- $R_{cable\ line_{max}}$ maximum total resistance,
- r_{core} maximum electrical DC resistance of power core with length 1 km.

The maximum allowed cable length shall be calculated by formula:

$$L_{cable\ line_{max}} = \frac{R_{cable\ line_{max}}}{2 \cdot r_{core}}, (km),$$

where $L_{cable\ line_{max}}$ – maximum power cable length, km,

$R_{cable\ line_{max}}$ – maximum total resistance of the cable, Ohm,

r_{core} – maximum electrical DC resistance of power core with length 1 km (at + 20°C), Ohm/km. These data are indicated in the cable quality certificate or according to GOST 22483-2012. Power is supplied over two cable cores, therefore both cores resistance shall be taken into account by adding value 2 to the denominator.

Maximum total resistance shall be calculated by formula:

$$R_{cable\ line_{max}} = \frac{U_{power\ supply} - U_{min}}{I_{consumption}} \text{ (Ohm)},$$

where $U_{power\ supply}$ – power supply voltage (for example, power unit, controller etc.), V,

U_{min} – minimum power supply voltage of the gas detector, V. For DGS ERIS-230 the minimum voltage is 13 V.

$I_{consumption}$ – consumption current of the gas detector at minimum power supply voltage, A. For DGS ERIS-230 this value is 0.525 A.

Example: For power supply of the gas detector DGS ERIS-230 one-core and multi-core cables and cables with circle stranded wires from flexible copper without coating of 3rd class produced in accordance with GOST 22483-2012 are used. Gas detector DGS ERIS-230 is powered from the controller SGM ERIS-130 by voltage 24V, i. e.:

$$U_{power\ supply} = 24\text{ V}, U_{min} = 13\text{ V}, I_{consumption} = 0,525\text{ A}, r_{core} = 39,6\text{ Ohm/km}.$$

Calculate maximum length of two-core cable:

$$R_{cable\ line_{max}} = \frac{24 - 13}{0,525} = 20,95\text{ Ohm}$$

$$L_{cable\ line_{max}} = \frac{20,95}{39,6 \cdot 2} = 0,26\text{ km}$$

Table 2 shows the maximum power cable length between the controller and detector.

Temperature corrections and actual cable quality are not considered in these calculations.

Table 2 – Maximum length of two-core power cable

Core section, mm ²	$R_{cable\ line_{max}}$, Ohm	r_{core} (at + 20°C), Ohm/km	$L_{cable\ line_{max}}$, km
0.50	20.95	39.6	0.26
0.75		25.5	0.41
1.0		21.8	0.48
1.5		14.0	0.74
2.5		7.49	1.39
4		4.79	2.18
6		3.11	3.36
10		1.99	5.26
16		1.21	8.65
25		0.809	12.94
35		0.551	19

12.3 Grounding procedure

Effective grounding is required to restrict influence of radio frequency interference and ensure electromagnetic compatibility.

Using the screened cable the screen covering circuit conductors protects them against parasitic capacitive couplings and external magnetic fields. This screen shall be connected

to the ground screw only at one end point, usually from controller side (Figure 22). The screen at the other end from the detector side shall be terminated or connected to a blank terminal.

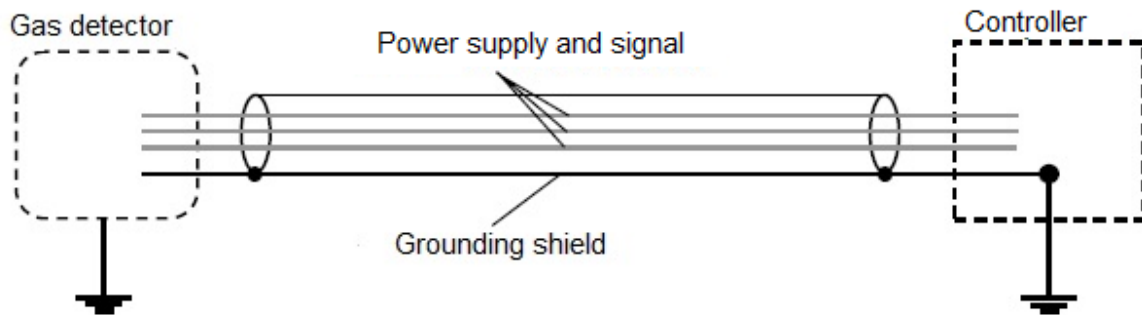
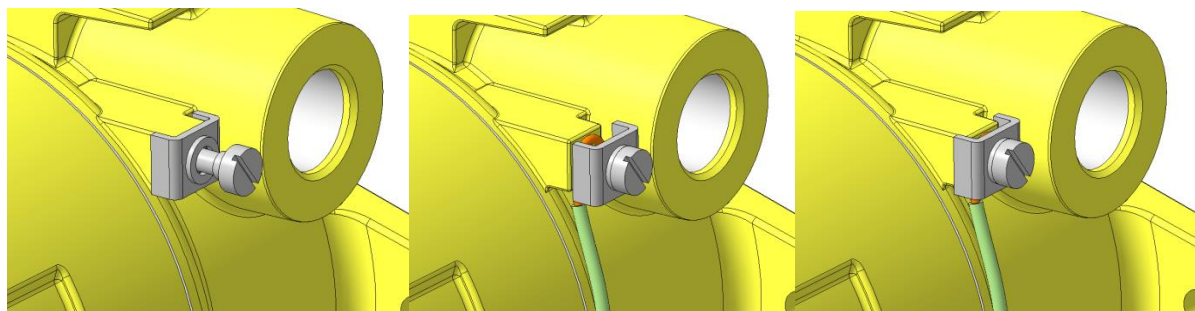

Figure 22 – Screened cable grounding

Do not ground the screen from both sides: currents inducing incorrect readings or false alarms could occur due to difference of potentials.

In accordance with clause 7.3 of Electrical Installations Code the housing of the gas detector shall be grounded in order to ensure protective grounding. The external ground screw and grounding sign are provided for this purpose according to GOST 21130-75. Specially indented for this purpose grounding conductors shall be used.

In order to connect the grounding conductor loosen the ground screw sufficiently to enable wrapping the wire around the screw in a “U” shape (Figure 23). Raise the clamp and place the wire between the clamp and the detector housing. Lower the clamp and tighten the ground screw.



a) loosen the screw

b) place the wire

c) tighten the screw

Figure 23 – Grounding of the gas detector housing

13 First time switch-on (commissioning)



Do not open the gas detector in an explosion hazard area when power supply is on.

Only trained personnel could have access to the internal parts of the gas detector for any works performance.

The gas detector housing shall be grounded. Internal and external grounding devices and earth signs according to GOST 21130-75 are available for gas detector ground connection.

Do not disassemble detectors and interchange detectors parts.

Do not expose the detector to temperatures out of the specified operation range.

Do not connect the gas detector to main supply line with 220 V. The manufacturer shall have no warranty obligation in case of such improper operation of the gas detector.

13.1 Check of power supply connection



Zero calibration is mandatory before the use of the gas detector for gas detection.

Refer to Section 16 for description of the corresponding procedure.

1) Screw off the lock screw on the upper cover of the gas detector cover (Figure 24). Screw off the cover. Remove the electronic module from connectors by pulling horizontally the semicircular handle "acr" (do not rotate).

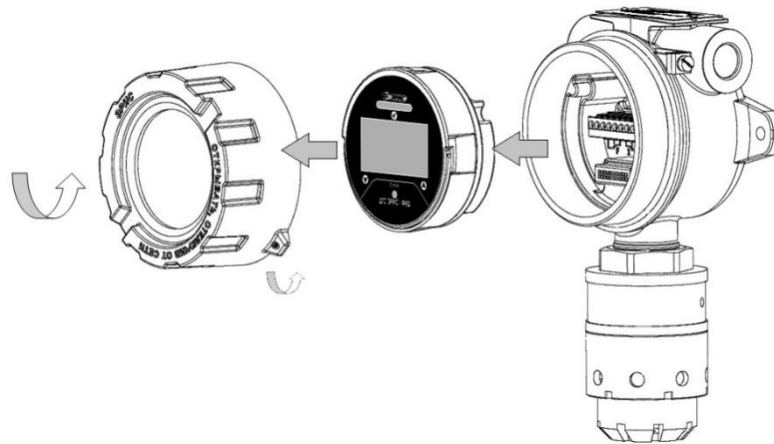

Figure 24 - Gas detector disassembling diagram

2) Make sure that all electrical connections are correctly joined according to Section 12.

3) After inspection the device shall be assembled in the in reverse order.



Ensure that none of terminal module wires cause an obstruction when refitting the electronic module. The socket of the electronic module shall be fully engaged in the connector of the terminal module.

4) Switch on external power supply of the gas detector.

5) Then start up procedure, initialization and warming up of the gas detector will be initiated (Table 3 and Table 4). Then the gas detector will turn to the measuring mode.

Table 3 – Interface status of DGS ERIS-230-1 with four digit LED indicator

Process	Digital indication	Visible alarm type
Start up	8888	LEDs blink red around a circle, Status LED glows white.
Initialization	8888	Red LED blinks around a circle. Status LED alternatively blinks red, green, and blue.
Warming up	0	Status LED blinks white once per second.
The gas detector functions properly*. Low value of volume concentration of detected gas (to value ALARM 1).	Concentration value	Status LED blinks green once per second.

Table 4 – Interface status of DGS ERIS-230-3 with OLED display

Process	Digital indication	Visible alarm type
Start up	DGS ERIS-230	Three LEDs glow red. Then red LEDs blink within 2 seconds. Status LED alternatively blinks all colours and stays in white.
Initialization / warming up	Initialization	Central Status LED blinks white once per second.
The gas detector functions properly*. Low value of volume concentration of detected gas (to value ALARM 1).	Concentration value	Status LED blinks green once per second.

* If the gas detector was not calibrated after installation, red glow after warming up mode does not mean the alarm limit exceeding. Perform zero calibration of the gas detector (Section 16).

Full description of each process and visible alarm type is given in Table 5 (DGS ERIS-230-1) and in Table 6 (DGS ERIS-230-3).

13.2 Installation inspection

Before the gas detector commissioning check the following:

1) Make sure that mounting bolts / nuts of the gas detector are securely tightened. Make sure that the gas detector could not be moved manually.

2) Make sure that cable entry / plug / audible and visible alarm are firmly tightened.

Torque:

- Cable entry - 40 Nm;
- Plug - 40 Nm;
- Lock nut of the audible and visible alarm - 25 Nm.

Make sure that cable entry and/or plug and/or audible and visible alarm could not be moved manually.

3) Make sure that the housing cover is firmly tightened, the lock screw is locked. Make sure that the gas detector cover could not be moved manually.

14 Indication and operability check

14.1 Indication check

The indication shall be checked after the first switch-on to ensure correct operation of device. Zero calibration is mandatory before the first switch-on of the gas detector.

When the gas detector is switched on in the area not containing flammable and toxic gases, the audible and visible alarm signals shall correspond to Tables 5 or 6. When the measured gases concentration exceeds the set alarm values or in case the failures occur, the audible and visible alarm of the gas detector shall correspond to Tables 5 or 6.

All indication signals and interface statuses are described in Tables 5 or 6. The audible and visible alarm operation statuses are described in Section 19.

Process		Visible alarm type	Current loop 4-20 mA	Digital indication	RS- 485MODBUS	Fault Relay*	Alarm 1 Relay*	Alarm 2 Relay*
The gas detector is switched off.		-	-	-	-	✓		
Preparation for measurement	Start up	LEDs glow red around a circle, Status LED glows white.	-	8888	-			
	Initialization	Red LED blinks around a circle. Status LED alternatively blinks red, green, blue.	-	8888	-			
	Warming up	Status LED blinks white once per second.	2	0	-			
Measurement	The gas detector functions properly. Low value of volume concentration of detected gas (to value ALARM 1).	Status LED blinks green once per second.	4-20	Concentration value	Concentration value and status code			
	Maximum volume concentration of detected gas exceeds set limit of ALARM 1	Status LED glows red. LEDs around a circle blink one time, once per second.	4-20	Concentration value	Concentration value and status code		✓	
	Maximum volume concentration of detected gas exceeds set limit of ALARM 2	Status LED glows red. LEDs around a circle blink two times, once per second.	4-20	Concentration value	Concentration value and status code		✓	✓

Span calibration (adjustment)	Calibration mode initialization (magnetic calibration)	Status LED blinks green 10 times per second and stays in pink.	4-20 turn to 2.6	Concentration value	Concentration value			
	Zero calibration	Status LED blinks pink one time.	2.6	Concentration value	–			
	Span calibration	Status LED blinks pink two times.	3.4	Concentration value	–			
	Data storage during magnetic calibration	Status LED blinks blue	1.0	Concentration value	Concentration value			
	Calibration mode exit (magnetic calibration)	Status LED blinks pink 10 times per second and stays in green.	3.4 turn to 4-20	Concentration value	Concentration value			
	Current output calibration 4 mA	Status LED blinks light-blue one time.	4	Concentration value	Concentration value			
	Current output calibration 20 mA	Status LED blinks light-blue two times.	20	Concentration value	Concentration value			
Failures	Indication range is exceeded	Status LED blinks yellow. LEDs shortly blink three times, once per second.	22	Concentration value	Concentration value and fault code	✓	✓/–	✓/–
	No communication with the sensor	Status LED glows yellow. Four LEDs shortly blink red around a circle three times, once per second.	1.5	– no –	Fault code	✓		
Note: *Default value. ✓ - Relay actuated.								

Table 6. DGS ERIS-230-1 interface statuses

Process		Visible alarm type	Current loop 4-20 mA	Display indication	RS-485MODBUS	Fault Relav*	Alarm 1 Relav*	Alarm 2 Relav*
The gas detector is switched off.		-	-	-	-	✓		
Preparation for measurement	Start up	Three LEDs glow red. LEDs blink within 2 seconds. Status LED alternatively blinks all colours and stays in white.	-	DGS ERIS-230	-			
	Initialization / warming up	Status LED blinks white once per second.	2	Initialization	-			
Measurement	The gas detector functions properly. Low value of volume concentration of detected gas (to value ALARM 1).	Status LED blinks green once per second.	4-20	Concentration value	Concentration value and status code			
	Maximum volume concentration of detected gas exceeds set limit of ALARM 1	Status LED glows red. Three LEDs blink red one time, once per second.	4-20	Concentration value / Alarm 1	Concentration value and status code		✓	
	Volume concentration of detected gas exceeds set limit of ALARM 2	Status LED glows red. Three LEDs blink red two times, once per second.	4-20	Concentration value / Alarm 2	Concentration value and status code		✓	✓
Span calibration (adjustment)	Zero calibration	"Status" LED blinks pink one time.	2.6	Calibration procedure process	-			
	Calibration	Status LED blinks pink two times.	3.4	Calibration procedure process	-			
	Current output calibration 4 mA	Status LED blinks light-blue one time.	4	Calibration procedure process	Concentration value			
	Current output calibration 20 mA	Status LED blinks light-blue two times.	20	Calibration procedure process	Concentration value			

Failures	Indication range is exceeded	Status LED blinks yellow. LEDs shortly blink three times, once per second.	22	Concentration value	Concentration value / fault code	✓	✓/ -	✓/ -
	No communication with the sensor	Status LED glows yellow. Two outer LEDs shortly blink red three times, once per second.	1.5	Open detector	Fault code	✓		
Note: *Default value. ✓ - Relay actuated.								

14.2 Relay activation test



The relay activation could be tested only if the gas detector supports such option. Maximum relay output shall not exceed 2 A.

To perform field calibration using the state standard sample of the calibration gas mixture, proceed as follows:

- 1) Fault relay test. To test the relay, switch on the gas detector. The fault signal shall be displayed on the control panel.
- 2) Alarm 1 relay test. To test the relay, supply the calibration gas mixture through the calibration cap of the gas detector, the measured gas concentration shall exceed the set value of Alarm 1. If the fault signal is displayed on the control panel, the relay operates correctly. Visual alarm signals of the gas detector shall correspond to Tables 5 or 6.
- 3) Alarm 2 relay test. To test the relay, supply the calibration gas mixture through the calibration cap of the gas detector, the measured gas concentration shall exceed the set value of Alarm 2. If the fault signal is displayed on the control panel, the relay operates correctly. Visual alarm signals of the gas detector shall correspond to Tables 5 or 6. Check of the gas detector relays operation is complete.

15 Gas detector operation

Gas detector DGS ERIS-230 is supplied configured and ready for use according to the default settings specified in clause 9.6.



Zero calibration (see Section 16) shall be performed after the gas detector installation, when zero calibration is complete the gas detector is ready for operation.

The Status LED glows GREEN during the normal operation or measuring mode.

LEDs blink RED if the gas concentration falls outside the low or high limits of alarm response (ALARM 1, ALARM 2).

The full list of gas detector indications is shown in Section 14, Tables 5 or 6.

Operation indications of the gas detector equipped with the audible and visible alarm is described in Section 19.

15.1 Operation mode structure

The gas detector has three operations modes.

1) Measuring mode is a normal device state, when the gas detector measures the gas concentration. In this mode the fault and warning statuses are regularly checked, and corresponding relay contacts are activated according to the set configuration.

2) Calibration mode is used to perform zero and span calibration of the sensor.

3) Configuration mode is used to change configuration parameters of the gas detector in accordance with the specific requirements.

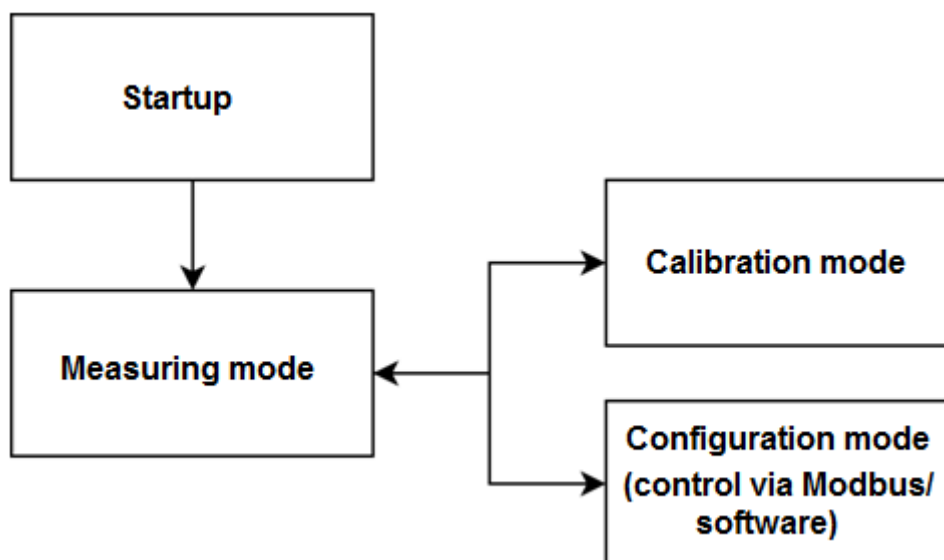

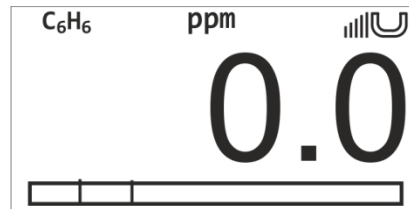

Figure 25-Operation mode structure

15.2 The main menu of gas detector DGS ERIS 230-3

For access to the main menu of the gas detector, attach the magnet to the sign  in the measuring mode, and hold the magnet for 5 seconds. The magnet sign and time-countdown (vertical bars) are displayed in the upper right corner of the screen. Then the main menu opens.



The main menu contains the following menu items:

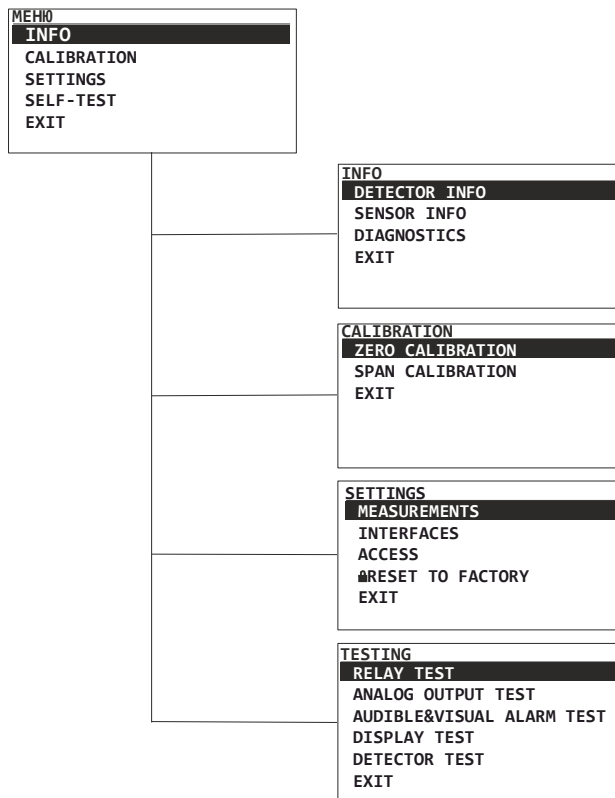





- INFO menu shows information on the gas detector, sensor and device diagnostics data.

- CALIBRATION menu helps to perform zero and span calibration of the gas detector using the magnetic wand and calibration gas mixture/zero gas.

- SETTINGS menu is used to set parameters of the gas detector, sensor, interfaces, and change access password.

- SELF-TEST menu is used to test the current output and relays, as well as to review gas detector information and automatically test the display.

To move through the menu items, attach the magnet to the corresponding sign  or .

For access to any menu item, attach the magnet to the sign  for a short time. To move from the lower to upper menu level or from the main menu to the measuring mode, select "Exit". The other way is to put the magnet to the sign  and hold it for 2 seconds.

The menu items identified by the sign  are available only for personnel of the manufacturing company and protected by the access password (factory settings). It is possible to set the password to restrict user access, for more details please refer to clause 15.2.3.3.

15.2.1 INFO menu

MENU	
TINFO	
CALIBRATION	
SETTINGS	
SELF-TEST	
EXIT	

The INFO menu contains information on the gas detector, sensor and device diagnostics data. The collected data on device failures shall be sent to the Technical Support Service of the manufacturing company, since it may help to identify the failure cause. Measurement range submenu could be edited by user, other menu items are accessible only for reading or could be edited only by personnel of the manufacturing company, such items are identified by the sign .

DETECTOR INFO	
SER .Nº:	ER 3160001
DET. TYPE :	DGS ERIS 230
HW VER. :	v.0.00.00
SW VER. :	v. 1.06.086
MEAS. RANGE .:	0.5/50.0
DISP. RANGE :	0.5/100.0
MEAS. UNIT :	ppm
DISP. UNIT :	ppm
SPAN GAS :	40.0
HANDLING, h:	103
RELAY:	YES
STATUS:	MEAS. MODE
FW UPDATE	
EXIT	

SENSOR INFO	
SER .Nº:	171171
SENSOR TYPE :	EC
HW VER. :	v.0.00.00
SW VER. :	v. 2.04.226
MEAS. UNIT :	ppm
MEAS. RANGE :	0.5/50.0
ADC MIN. VALUE :	3501
ADC MAX. VALUE :	499
MEAS. VALUE :	0.0
MOLAR MASS:	34.1
HANDLING, h:	102
OPT. AMP. SETTINGS	
EXIT	

DIAGNOSTICS	
SUPPLY VOLTAGE .V:	23.3
Iout ,mA:	4.13
Uout ,V:	20.23
Rout ,Ohm:	500
U DET. 3.3, V:	3.3
U DET. 5.0, V:	5.1
DET. TEMP. ,C:	33.0
U SENS. 3.3, V:	3.2
U SENS. 5.0, V:	4.9
Usens ,mV:	3537
SENS. TEMP. ,C:	26.5
EXIT	

Detector Info submenu shows information on the gas detector including serial number, type, hardware version, software version, sensor measurement range, analog output measurement range, measuring units and displayed units, last calibration concentration, handling (in hours), relay, status.

Sensor Info submenu shows information on the sensor that is a part of the gas detector, i.e. sensor serial number, gas type, hardware version, software version, measurement range, ADC minimum and maximum values, current concentration, molar mass, handling (in hours), etc.

Diagnostics submenu shows the information on device diagnostics, i.e. supply voltage of the gas detector, current, resistance, sensor temperature, sensor voltage, etc.

15.2.2 CALIBRATION menu

CALIBRATION	
ZERO CALIBRATION	
SPAN CALIBRATION	
EXIT	

The CALIBRATION menu contains the following menu items: ZERO CALIBRATION, SPAN CALIBRATION. Calibration procedure and methods are described in details in Section 16.

15.2.3 SETTINGS menu

The Settings menu contains the following menu items: MEASUREMENTS, INTERFACE SETTING, ACCESS, RESET TO FACTORY.

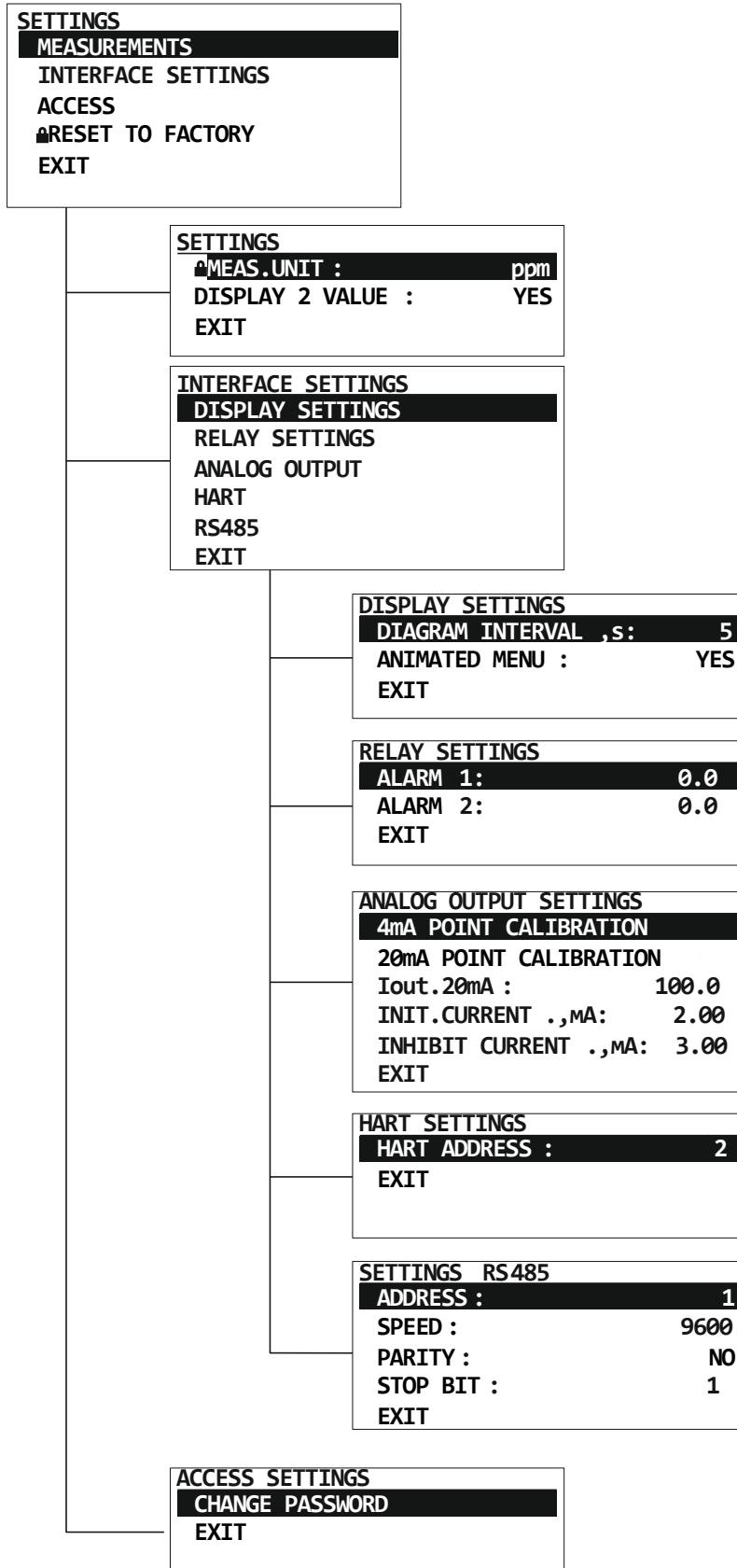

15.2.3.1 MEASUREMENTS submenu

MEASUREMENTS submenu is used to configure gas detector measurement parameters. Two concentrations in mg/m³ and ppm could be display simultaneously.

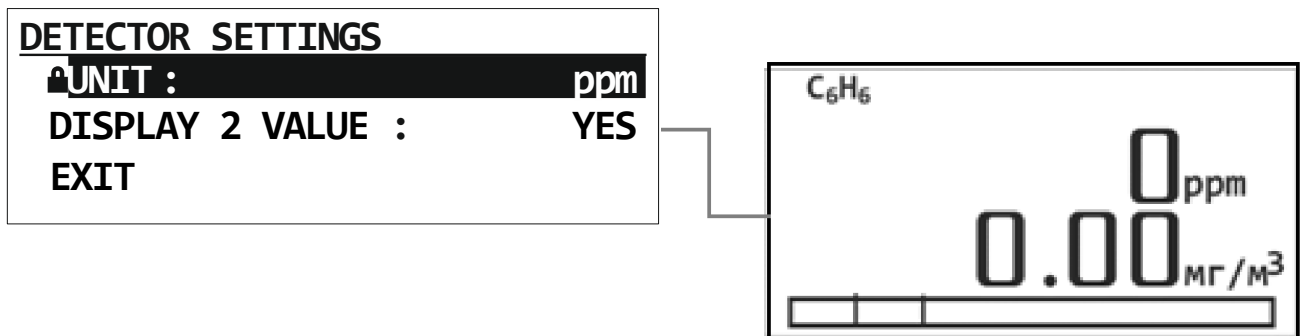

15.2.3.2 INTERFACES SETTINGS submenu

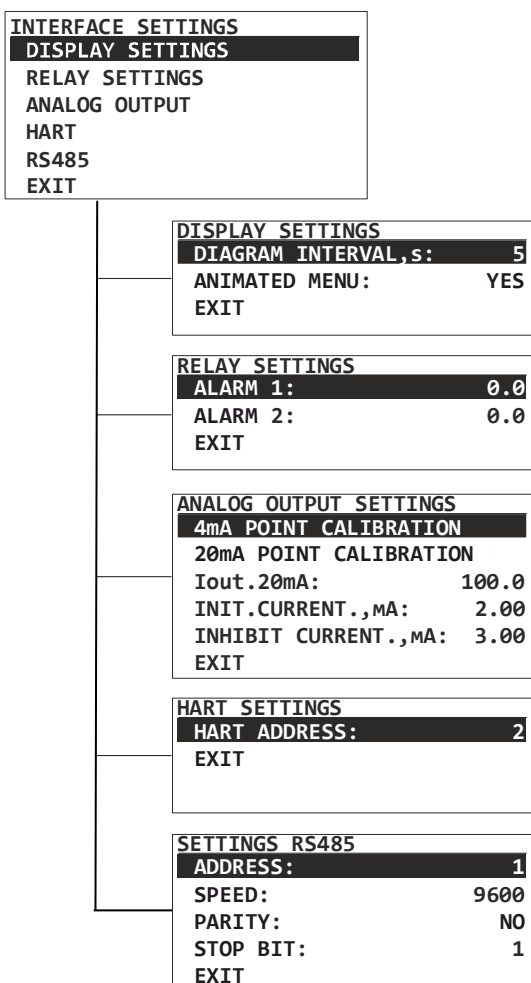

Configuration of setting parameters could be performed in the following ways:

- attach the magnet to signs or and move to required parameter
- enter the parameter edit mode by placing the magnet over the sign
- hold the magnet over signs or for 2 seconds to move between digit positions (selected position blinks)
- put the magnet over signs or for a short time to change the selected digit position
- hold the magnet over the sign for 2 seconds to save changed parameter and exit the edit mode. Put the magnet over the sign to exit the edit mode without change saving.

1) DISPLAY SETTINGS submenu allows to turn on/off animated menu, set the collection interval of data required to build the diagram indicating concentration measured during the gas detector operation (clause 4.5).

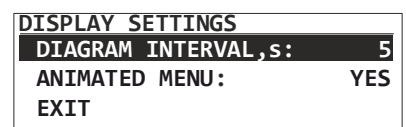

2) RELAY SETTINGS submenu is used to set Alarm 1 and Alarm 2 using the following parameters: activation, hysteresis, delay.

RELAY SETTINGS	
ALARM 1:	0.0
ALARM 2:	0.0
EXIT	

ALARM 1 SETTINGS		ALARM 2 SETTINGS	
ALARM :	5.0	ALARM :	10.0
HYSTERESIS :	0.2	HYSTERESIS :	0.2
ACTIVATION :	RISE	ACTIVATION :	RISE
DELAY ,s:	1	DELAY ,s:	1
EXIT		EXIT	

3) ANALOG OUTPUT SETTINGS submenu is used to calibrate current output in points of 4 mA and 20 mA.

To start calibration of the current output in point of 4 mA, select "Yes". When the target screen appears, enter the current output value (default value is 4.00 mA) and the measured current value of gas detector analog output. Select "Save" to save changes. Select "Cancel" to interrupt the calibration of the current output. When calibration is finished, the following status message is displayed for several seconds: "FINISHING OUTPUT CALIBRATION". Then the gas detector turns back to the ANALOG OUTPUT CALIBRATION submenu.

ANALOG OUTPUT SETTINGS	
POINT 4mA CALIBRATION	
POINT 20mA CALIBRATION	
Iout.20mA:	100.0
INIT.CURRENT, mA:	2.00
INHIBIT CURRENT, mA:	3.00
EXIT	

POINT 4mA CALIBRATION	
START mA OUTPUT CALIBRATION ?	
▶NO◀	YES

POINT 4mA CALIBRATION	
SAMPLE	MEASURED
4.00 mA	4.00 mA
▶ESC◀	SAVE

POINT 4mA CALIBRATION	
FINISHING OUTPUT CALIBRATION	

To start calibration of the current output in point of 20 mA, select "Yes". When the target screen appears, enter the current output value (default value is 20.00 mA) and the measured current value of gas detector analog output. Select "Save" to save changes. Select "Cancel" to interrupt the calibration of the current output. When calibration is finished, the following status message is displayed for several seconds: "FINISHING OUTPUT CALIBRATION". Then the gas detector turns back to the CALIBRATION menu.

POINT 20mA CALIBRATION	
START mA OUTPUT CALIBRATION ?	
▶NO◀	YES

POINT 20mA CALIBRATION	
SAMPLE	MEASURED
20.00 mA	4.00 mA
▶ESC◀	SAVE

POINT 20mA CALIBRATION	
FINISHING OUTPUT CALIBRATION	

4) HART SETTINGS submenu is used to change HART address.

HART SETTINGS	
HART ADDRESS:	2
EXIT	

5) SETTINGS RS485 submenu is used to change the gas detector network address and RS485 speed.

SETTINGS RS485	
ADDRESS:	1
SPEED:	9600
PARITY:	NO
STOP BIT:	1
EXIT	

15.2.3.3 ACCESS submenu

ACCESS submenu is used to change the access password. Setting a password restricts access to the following menu items:



MENU>>INFO>>DETECTOR INFO>>MEASUREMENT RANGE.

MENU>>CALIBRATION>>ZERO CALIBRATION.







MENU>>CALIBRATION>>SPAN CALIBRATION.

MENU>>SETTINGS>>MEASUREMENTS.

MENU>>SETTINGS>>ACCESS.

MENU>>SETTINGS>>RESET TO FACTORY.

The password is edited and saved likewise the sensor:

- enter the password edit mode by placing the magnet over the sign 
- hold the magnet over the signs  or  for 2 seconds to move between digit positions (selected position blinks)
- put the magnet over the signs  or  for a short time to change the selected digit position
- hold the magnet over the sign  for 2 seconds to save password and return to ACCESS submenu. Put the magnet over the sign  to exit the edit mode without change saving.



The default password is 0000.

15.2.3.4 RESET TO FACTORY submenu

RESET TO FACTORY submenu is used to reset the parameters to the factory settings.

TESTING**RELAY TEST**

ANALOG OUTPUT TEST
 AUDIBLE&VISUAL ALARM TEST
 DISPLAY TEST
 DETECTOR TEST
 EXIT

15.2.4 TESTING menu

The Testing menu contains the following menu items: RELAY TEST, ANALOG OUTPUT TEST, AUDIBLE&VISUAL ALARM TEST, DISPLAY TEST, DETECTOR TEST.

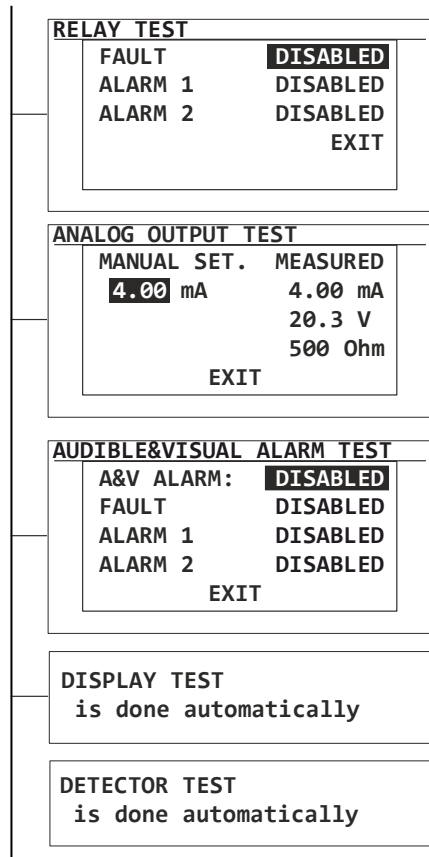
**15.2.4.1 RELAY TEST submenu**

RELAY TEST submenu is used to test relay outputs of the gas detector. When the magnet is attached to the sign , the corresponding relay could be switched on/off.

15.2.4.2 ANALOG OUTPUT TEST submenu

ANALOG OUTPUT TEST submenu is used to test analog output of 4–20 mA. Enter any current value within the range of 4.00–20.00 mA into MANUAL SET. column and check current output value in MEASURED column and at the gas detector current output. In case of unsatisfactory results, recalibrate the current output in ANALOG OUTPUT TEST menu.

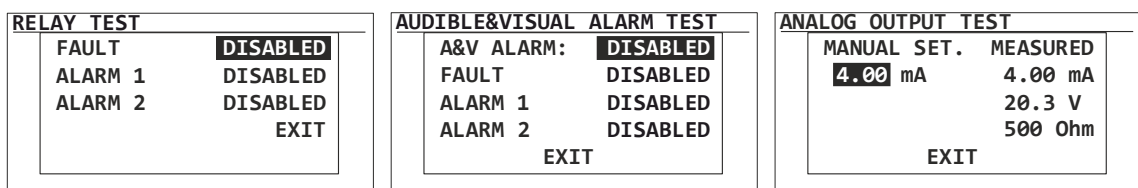
**15.2.4.3 AUDIBLE&VISUAL ALARM TEST submenu**

AUDIBLE&VISUAL ALARM TEST submenu is used to test the audible and visible alarm. AUDIBLE&VISUAL ALARM TEST column shall contain entry "Yes". When the magnet is attached to the sign , the corresponding variable could be switched on/off, thus alarm operability is checked.

15.2.4.4 DISPLAY TEST submenu

The display testing is performed automatically followed by display animating. When the test is complete, the following message is displayed: "Test is complete".

15.2.4.5 DETECTOR TEST submenu

The gas detector testing is performed automatically during the whole period of device operation.



16 Zero calibration and span calibration

Do not operate the gas detector with mechanical damages of the housing or damaged seal.

Do not open the gas detector in the explosion hazard area when power supply is on.

Only trained personnel could have access to the internal parts of the gas detector for any kind of works.

The gas detector housing shall be grounded. Internal and external grounding devices and earth signs according to GOST 21130-75 are envisaged for gas detector ground connection.

Do not disassemble gas detectors and interchange detectors' parts.

Do not discharge state standard sample of the calibration gas mixture in the atmosphere of working premises during the gas detector adjustment and verification.

When the power supply is on, the gas detector shall be held switched on within the following periods of time before the calibration is performed:

DGS ERIS-230EC – 1 hour;

DGS ERIS-230CT – 1 hour;

DGS ERIS-230IR – 10 min;

DGS ERIS-230EC(O₂) – 24 hours.

In zeroing and span calibration mode the current output from the gas detector is inhibited (default 2.6 mA and 3.4 mA correspondingly) to avoid false alarms.

If the area, where the gas detector is installed, contains any residual amount of measured gas, then zero gas cylinder shall be applied for zero calibration. If there is no measured gas, then ambient air could be used for zero calibration. Zero grade air or nitrogen of high purity

is recommended to use as a zero gas (nitrogen must not be used for DGS ERIS-230CT).



Zero calibration is not required for an oxygen gas detector. The oxygen gas detector could be calibrated using ambient air (20.9% vol. oxygen). Zero calibration shall be performed using nitrogen (N₂).



To achieve required accuracy of the span calibration the concentration of applied span gas shall lay within 25–75% of measurement range.

The gas detector calibration requires the corresponding gas cylinder, constant flow regulator and calibration cap (see Section 5). The flow rate used for different calibration gases is shown below:

Gas type	Flow rate (l/min)
Air or N ₂ for zero calibration	from 0.5 to 1.0
Flammable gases (thermocatalitic sensor)	from 1 to 1.5
O ₂	from 0.5 to 1.0
H ₂ S	from 0.5 to 1.0
CO	from 0.5 to 1.0
H ₂	from 0.5 to 1.0
Toxic gases	from 0.5 to 1.0
Flammable gases (infrared sensor)	from 0.4 to 0.6
CO ₂	from 0.4 to 0.6

16. Zero calibration using the magnetic wand

① Zero calibration using the magnet requires the following equipment:

- 1 – DGS ERIS-230;
- 2 – magnetic wand;
- 3 – variable area flow meter;
- 4 – zero gas or pure air without any residual amount of the measured gas.

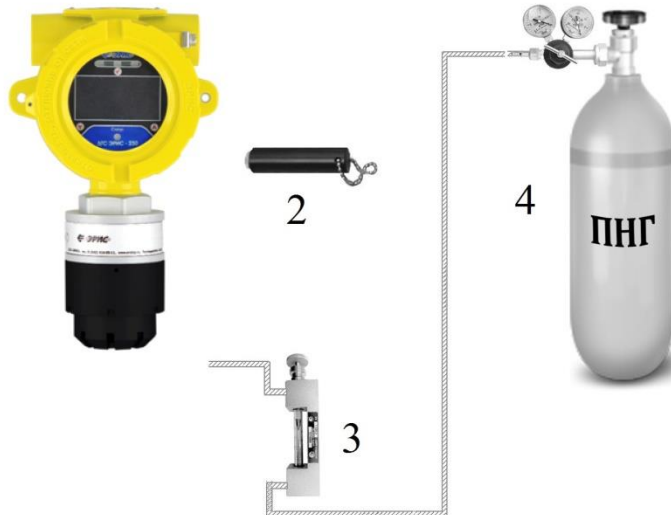

If the ambient air is NOT POSSIBLE to use as the reliable calibration gas to set ZERO, then remove the moisture protection cap, install the calibration cap (see Section 5) onto the gas detector and connect the zero gas cylinder.



Zero calibration of an oxygen gas detector shall be performed using nitrogen (N₂).

② For access to the Calibration menu, attach the magnet to area , hold for two seconds and remove. Status LED will start blinking green (ten times per second), then turns to zero calibration mode and blinks pink one time per second.



③ If zero gas is used to set zero, turn on zero gas supply through the calibration cap. Gas flow rate shall be from 0.5 to 1.0 l/min.



④ After 3 minutes put the magnet over the area  for a short time. Data saving process will start. Status LED blinks blue during 5 seconds.

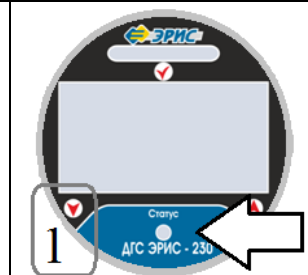

⑤ If zero gas is used to set zero, turn off zero gas supply. Zero calibration is complete and saved.



⑥ Then menu turns to the zero calibration mode. Status LED blinks pink one time per second.



⑦ If span calibration is not required, put the magnet over the "Enter" area for a short period of time, the gas detector turns to the measuring mode (Status LED blinks green one time per second), or in 2 minutes the gas detector will turn to the measuring mode automatically.

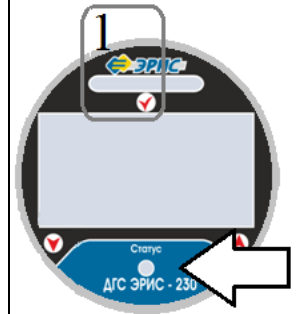

16.2 Span calibration using the magnetic wand

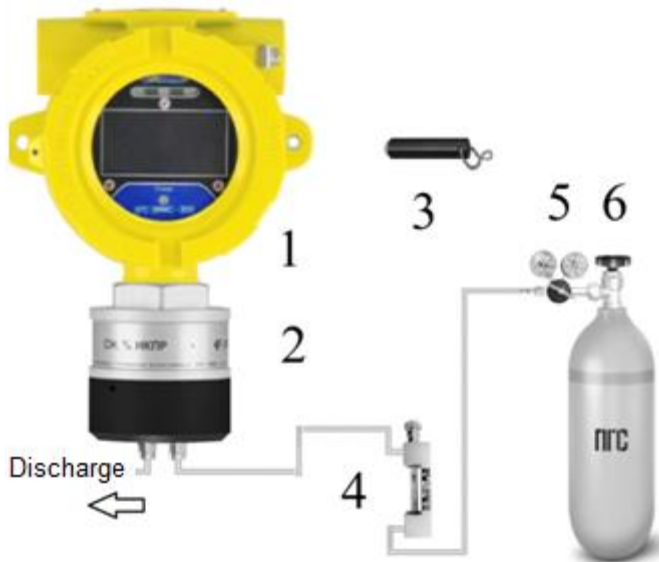

① Span calibration using the magnet requires the following equipment:







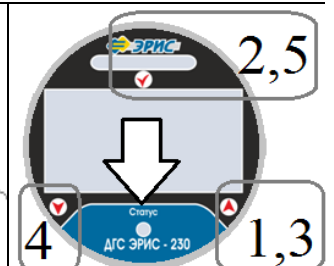
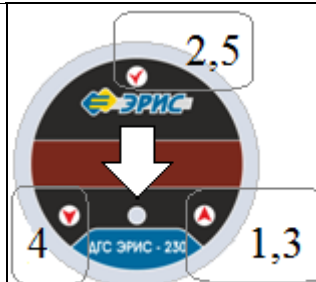

- 1 – DGS ERIS-230;
- 2 – calibration cap;
- 3 – magnetic wand;
- 4 – variable area flow meter;
- 5 – pressure regulator;
- 6 – state standard sample of the calibration gas mixture.

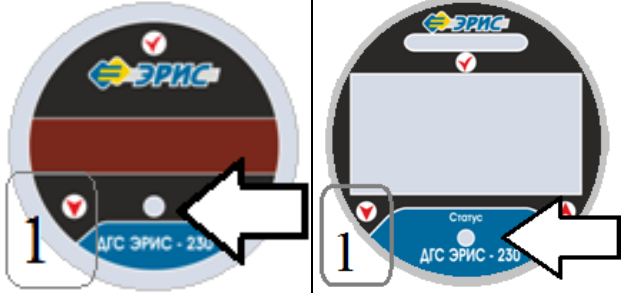

Span calibration of an oxygen gas detector could be performed using ambient air (20.9% vol. oxygen).

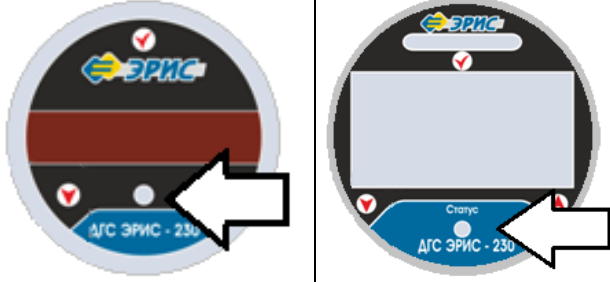
② Attach the magnet to the magnet areas in the following sequence: (▲), (▼), (▲), (▼), (▼). The gas detector will turn to the span calibration mode. Status LED blinks pink twice, one time per second.

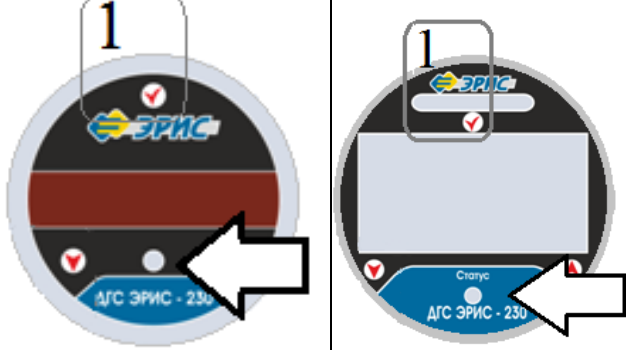

<p>③ Supply state standard sample of the calibration gas mixture through the calibration cap (the concentration shall be 25–75% of measurement range).</p>	
<p>④ After 3 minutes put the magnet over the area  for a short time. Data saving process will start. Status LED blinks blue during 5 seconds.</p>	
<p>⑤ Turn off the calibration mixture supply. Span calibration is complete and saved.</p>	
<p>⑥ Then menu turns to the span calibration mode (if required, data saving could be repeated). Status LED blinks pink one time per second.</p>	
<p>⑦ Leave calibration menu by attaching the magnet to the "Enter" area . If the magnet is not attached, the gas detector stays in the span calibration mode for 5 minutes, then turns to the measuring mode. (Status LED will start blinking green one time per second).</p>	
<p> ⑧ <i>It is essential to change the calibration cap with the moisture protection cap after each span calibration.</i></p>	

16.3 Zero calibration by means of DGS ERIS-230-3 menu

① Zero calibration requires the following equipment:

- 1 – DGS ERIS-230;
- 2 – magnetic wand;
- 3 – variable area flow meter;
- 4 – zero gas or pure air without any residual amount of the measured gas.

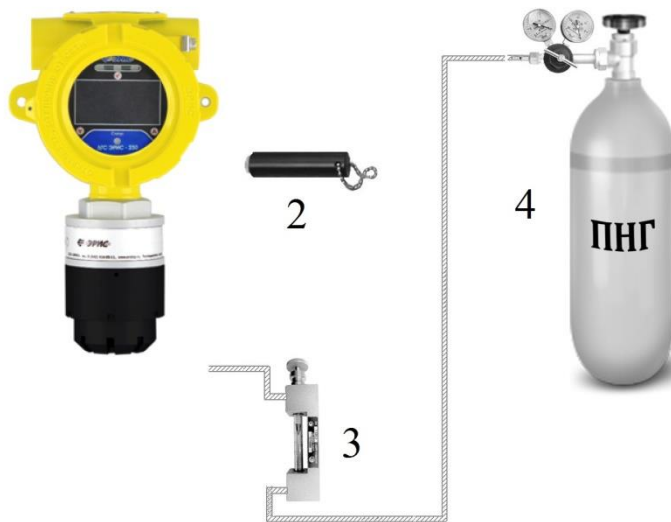



If the ambient air is NOT POSSIBLE to use as the reliable calibration gas to set ZERO, then remove the moisture protection cap, install the calibration cap (see Section 5) onto the gas detector and connect the zero gas cylinder.

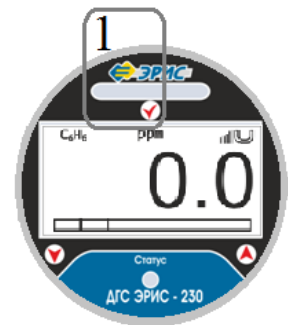

 Zero calibration of an oxygen gas detector shall be performed using nitrogen (N₂).

② For access to the main menu of the gas detector, attach the magnet to the sign  in the measuring mode and hold the magnet for 5 seconds. The magnet sign and time-countdown (vertical bars) are displayed in the upper right corner of the screen.



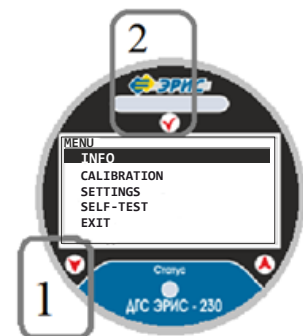







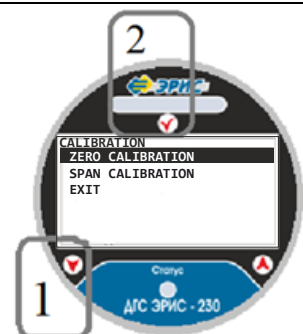







③ Then the main menu opens. To move through the menu items, attach the magnet to the corresponding sign  CALIBRATION. Attach the magnet to the sign  for a short time.

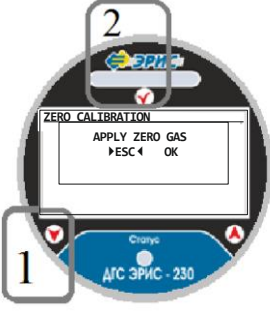

④ In the appeared window select ZERO CALIBRATION using corresponding signs  or  to move through the menu items.

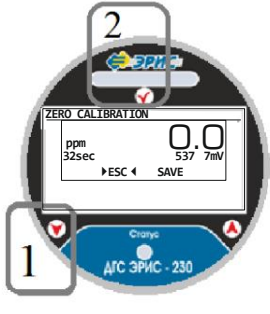
Attach the magnet to the sign  for a short time.



<p>5 To start the procedure, select "Yes" using corresponding signs  or .</p> <p>Attach the magnet to the sign  for a short time.</p>	
<p>6 If zero gas is used to set zero, turn on zero gas supply through the calibration cap. Gas flow rate shall be from 0.5 to 1.0 l/min.</p>	
<p>7 To start the procedure, select "Continue" using corresponding signs  or .</p> <p>Attach the magnet to the sign  for a short time.</p>	
<p>8 Zero calibration lasts minimum for 30 seconds. Then select "Save" using corresponding signs  or .</p> <p>Attach the magnet to the sign  for a short time.</p>	
<p>9 If zero gas is used to set zero, turn off zero gas supply. Zero calibration is complete and saved.</p>	
<p>10 When calibration is finished, the following status message is displayed for several seconds: "FINISHING ZERO CALIBRATION". Then the gas detector turns back to the CALIBRATION menu.</p> <p>Attach the magnet to the sign  for a short time.</p>	

16.4 Span calibration by means of DGS ERIS-230-3 menu

① Span calibration using the magnet requires the following equipment:

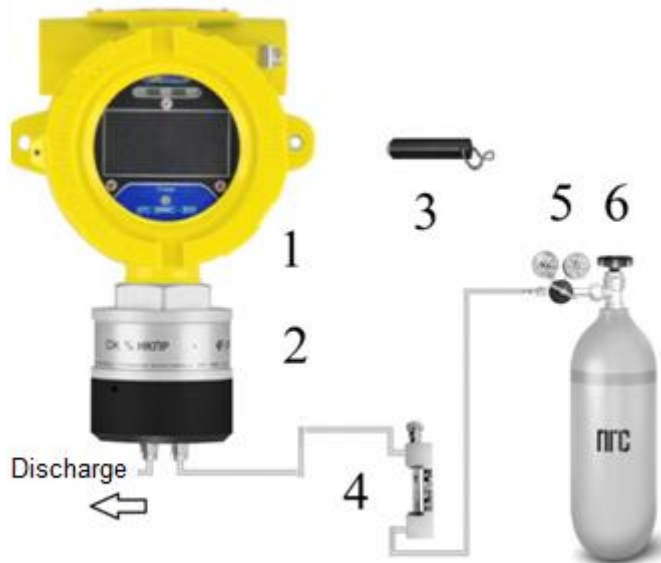



- 1 – DGS ERIS-230;
- 2 – calibration cap;
- 3 – magnetic wand;
- 4 – variable area flow meter;
- 5 – pressure regulator;
- 6 – state standard sample of the calibration gas mixture.



Span calibration of an oxygen gas detector could be performed using ambient air (20.9% vol. oxygen).

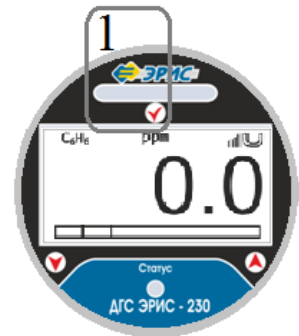

② For access to the main menu of the gas detector (normal operation mode), attach the magnet to the sign  in the measuring mode and hold the magnet for 5 seconds. The magnet sign and time-countdown (vertical bars) are displayed in the upper right corner of the screen.



③ Select CALIBRATION in the appeared main menu. To move through the menu items, attach the magnet to the sign .

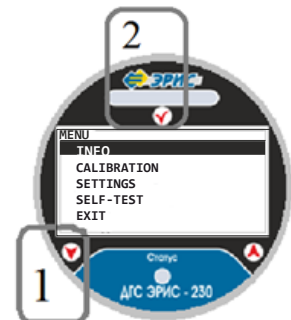

For access attach the magnet to the sign  for a short time.



④ In the appeared window select SPAN CALIBRATION using corresponding signs  or  to move through the menu items.

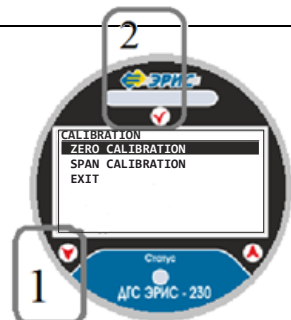







For access to SPAN CALIBRATION, attach the magnet to the sign  for a short time.







5 To start the procedure, select "Yes" using corresponding signs  or .
Attach the magnet to the sign  for a short time.



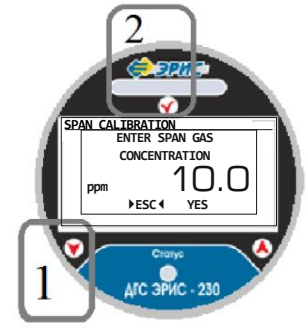



6 Then enter the supplied gas calibration*.
*Default is the concentration set in the DETECTOR SETTINGS submenu.
To change set values, proceed as follows:

- 1) Use corresponding signs  or  to move through the menu items. Turn to the concentration value, the digits starts blinking and background colour turns from yellow to black.
- 2) Attach the magnet to the sign  for a short time. Digit change mode is activated.
- 3) Numeric parameters are changed by one symbol at a time. To select the digit subject to change, put and hold the magnetic wand over the sign  or . The target digit will start blinking.
- 4) For a short time put the magnet over the sign  or  to adjust the value.
- 5) To save the set value, put the magnet over the sign  for a short time.

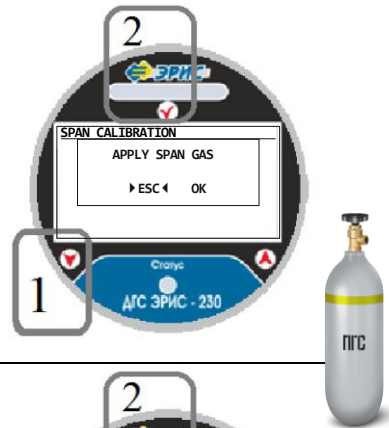

7 To start the procedure, select "Continue" using corresponding signs  or .
Supply the state standard sample of the calibration gas mixture (reference gas) with concentration of 25–75% of measurement range to the gas detector using the calibration cap.
Attach the magnet to the sign  for a short time.



8 Span calibration lasts minimum for 30 seconds. Then save calibration parameters.
Use corresponding signs  or  or select "Save".
Attach the magnet to the sign  for a short time.

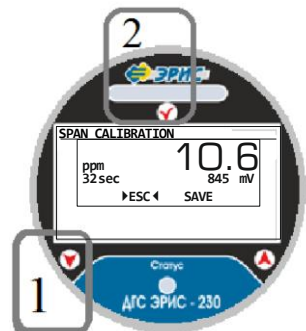

9 Turn off the calibration gas mixture supply.

When calibration is finished, the following status message is displayed for several seconds: "FINISHING SPAN CALIBRATION". Then the gas detector turns back to the CALIBRATION menu.

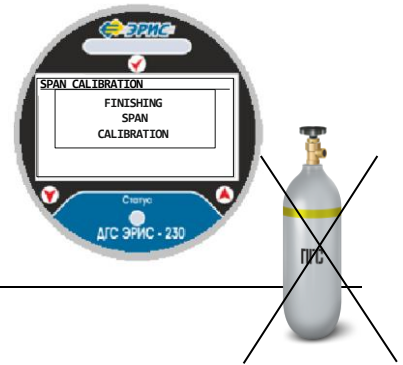

16.5 Zero calibration using HART communicator

Detailed description of supported commands, HART communication protocol, as well as HART menu is stipulated in Section 20.



Your gas detector shall support this option. Check that HART connector is available in the left threaded port. If there is no HART connector, HART communication is possible using the current loop according to Figures 18 and 19.

① Zero calibration requires the following equipment:

- 1 – DGS ERIS-230 with HART connector or option to use the current loop for HART communication;
- 2 – HART communicator;
- 3 – zero gas or pure air without any residual amount of the measured gas.



If the ambient air is NOT POSSIBLE to use as the reliable calibration gas to set ZERO, then remove the moisture protection cap, install the calibration cap (see Section 5) onto the gas detector and connect the zero gas cylinder.

② Switch on HART communicator (if required, move from the main menu to communication setting submenu) and wait for connection with the gas detector.

When connection is successful, the main menu will appear.

Select SETTINGS menu

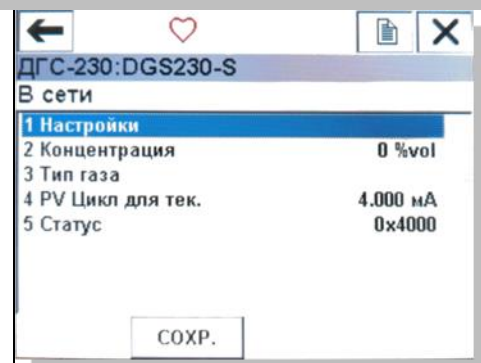

③ Select CALIBRATION

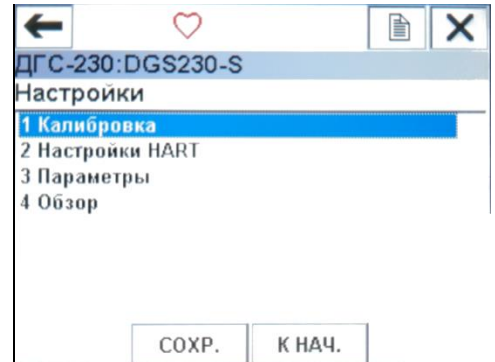

④ Select CALIBRATE SENSOR

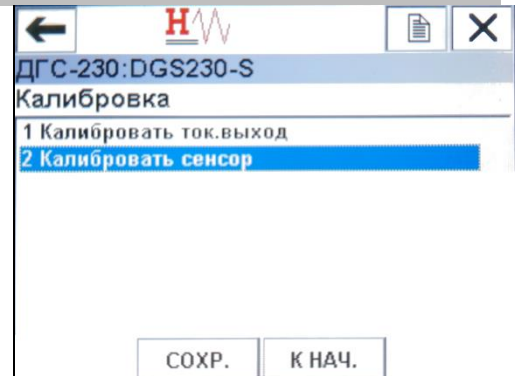

⑤ For zero calibration select ZERO CALIBRATION

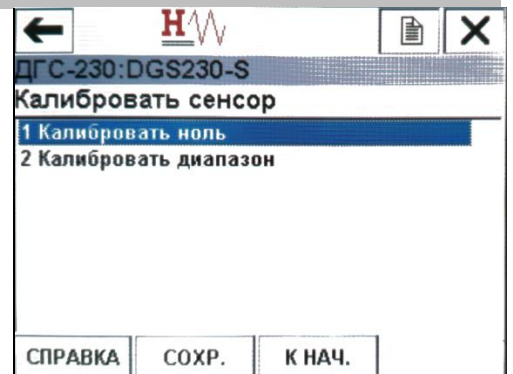

⑥ The following warning will appear:

"Switch off circuit automatic operation".

It means that current output value is fixed and does not correspond to the sensor reading (only for this operation).

Press "OK"

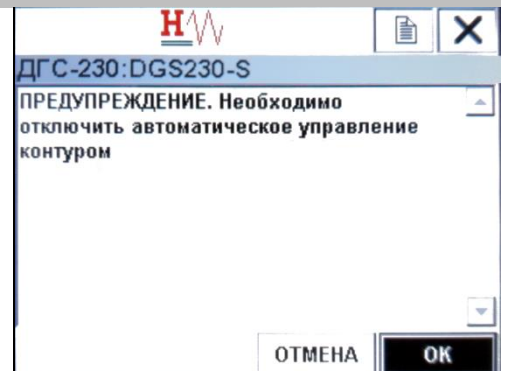

⑦ Then the following warning will appear:

"It will affect sensor calibration".

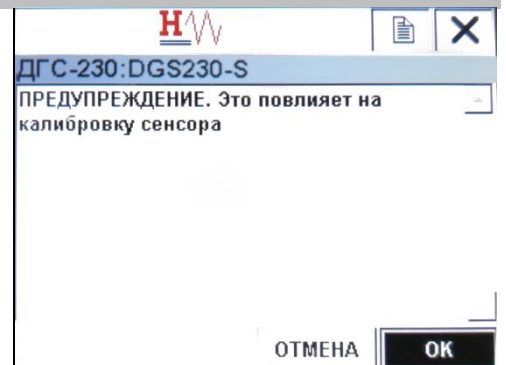

⑧ The following message will be displayed "Apply input 0 to sensor". Ensure that the gas detector is calibrated in the area without any residual amounts of the measured gas, otherwise supply zero gas to gas detector DGS ERIS-230.

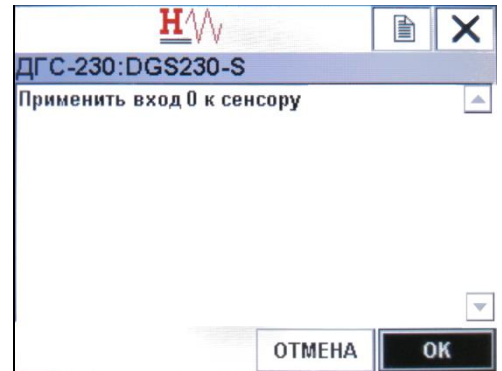

⑨ Press "OK" and allow the sensor to stabilize.

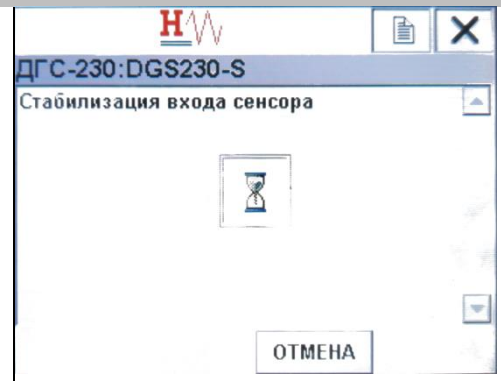

⑩ The notification window will appear stating that zero calibration is complete.

If zero gas is used to set zero, turn off zero gas supply.

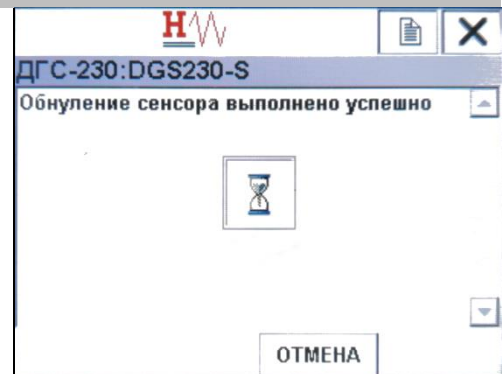

⑪ Zero calibration is complete. The following note will appear: "It is possible to return to circuit automatic operation"

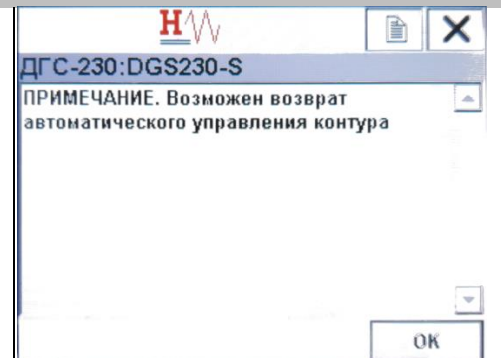

16.6 Span calibration using HART communicator

Detailed description of supported commands, HART communication protocol, as well as HART menu is stipulated in Section 20.



Your gas detector shall support this option. Check that HART connector is available in the left threaded port. If there is no HART connector, HART communication is possible using the current loop according to Figures 18 and 19.

① Span calibration requires the following:

- 1 – DGS ERIS-230 with HART connector or option to use the current loop for HART communication;
- 2 – HART communicator;
- 3 – zero gas or pure air without any residual amount of the measured gas.
- 4 – state standard sample of calibration gas mixture. If the ambient air is NOT POSSIBLE to use as the reliable calibration gas to set ZERO, then remove the moisture protection cap, install the calibration cap (see Section 5) onto the gas detector and connect the zero gas cylinder.



- ② Switch on HART communicator (if required, move from the main menu to communication setting submenu) and wait for connection with the gas detector. When connection is successful, the main menu will appear.

Select SETTINGS menu

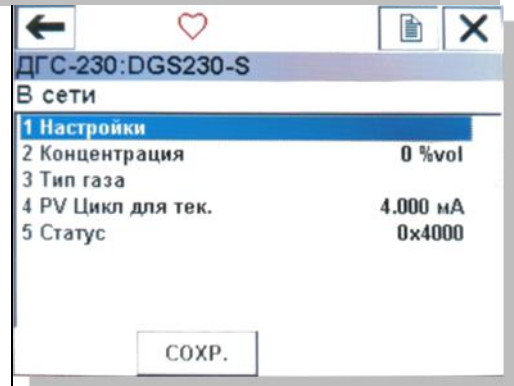

- ③ Select CALIBRATION

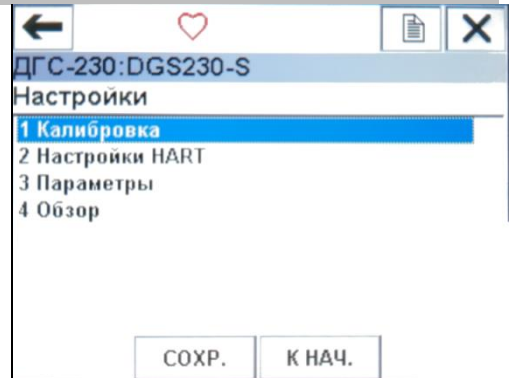

- ④ Select CALIBRATE SENSOR

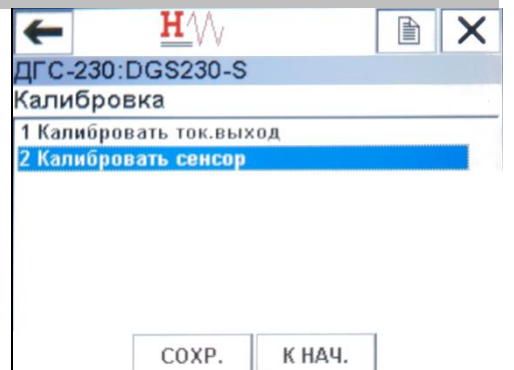

- 5 For span calibration of the sensor, select SPAN CALIBRATION.

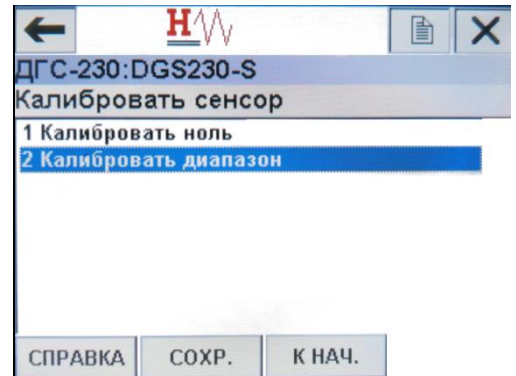

- 6 The following warning will appear:

"Switch off circuit automatic operation".

It means that current output value is fixed and does not correspond to the sensor reading (only for this operation).

Press "OK"

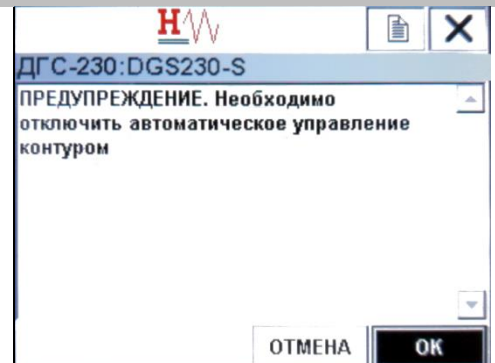

Then the following warning will appear:

"It will affect sensor calibration"

Press "OK"

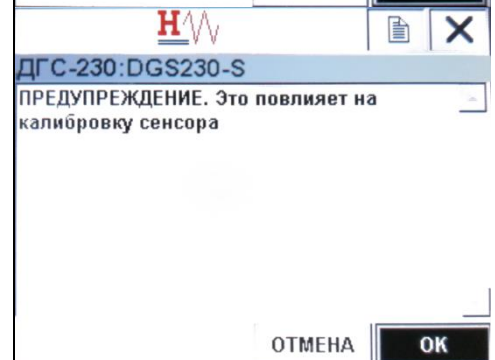

- 7 The following message will be displayed "Apply input 0 to sensor". (0% vol.)".

Ensure that the gas detector is calibrated in the area without any residual amounts of the measured gas, otherwise supply zero gas to gas detector DGS ERIS-230.

Enter "0" value.

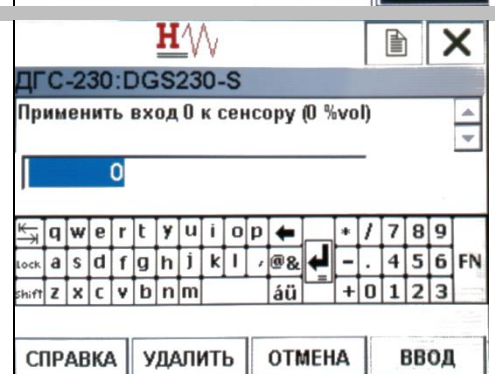

- 8 The readings of "Applied process" line shall be equal to "0% vol.", then press "Yes".

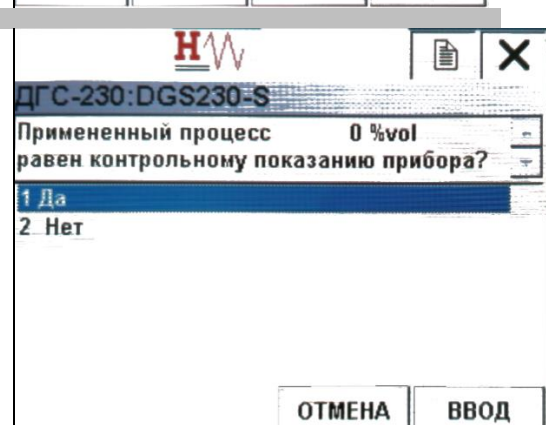

- ⑨ Supply the state standard sample of the calibration gas mixture for span calibration.
After 3 minutes enter the applied concentration value in the input box.

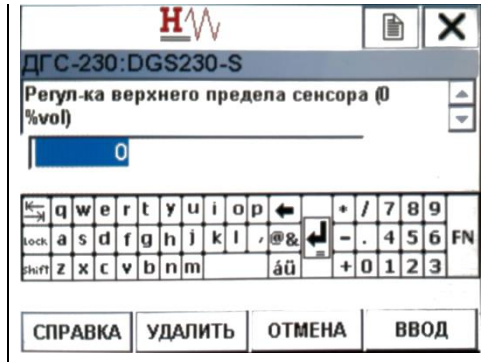

- ⑩ The readings of "Applied process" line shall be equal to "X% vol.".

X – value entered in item ⑨ for span calibration.

If the values coincide with the entered concentration, press "Yes".

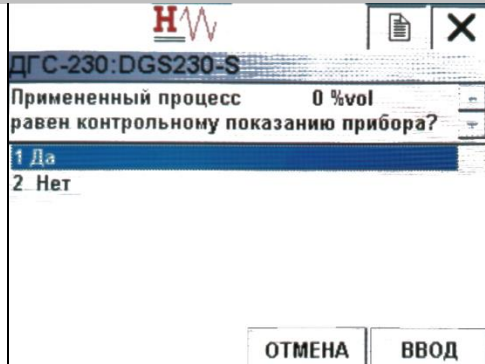

- ⑪ The span calibration is complete. The following note will appear: "It is possible to return to circuit automatic operation".

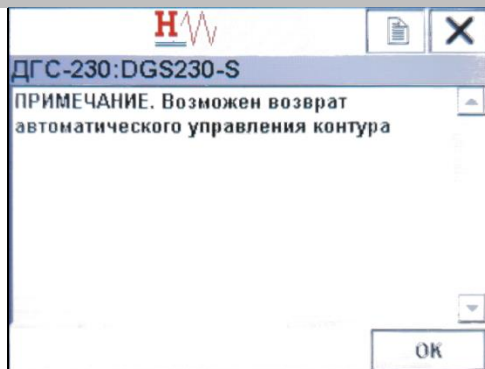

16.7 Zero calibration using PC with installed software*



*Please refer to www.eriskip.com. for free software and software manual.

The full list of RS485 registers of the gas detector is specified in Section 21.

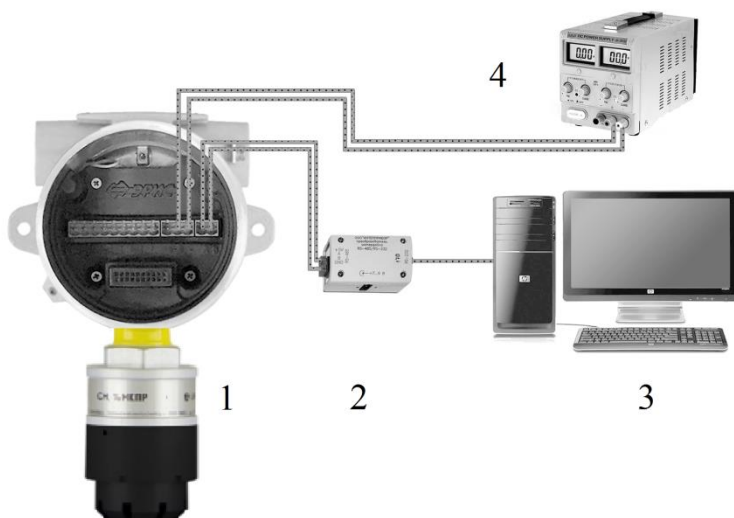

① Zero calibration requires the following equipment:

- 1 – gas detector DGS ERIS-230;
- 2 – RS485/USB transmitter;
- 3 – PC with installed software*;
- 4 – power supply source.

② Open the program, set the connection:

Select the gas detector connection port

Enter the device address in MODBUS line. The device address is two last digits of the serial number.

Example: Port: COM15.

Serial No. ER0000000011

Modbus:11

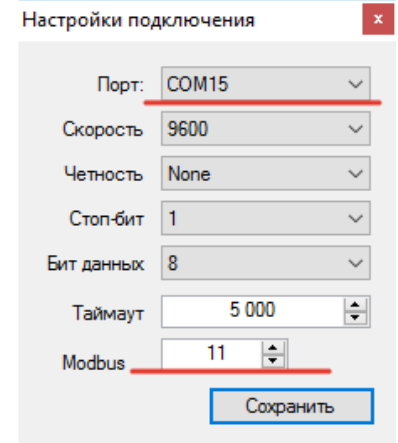

③ Click "Start" button

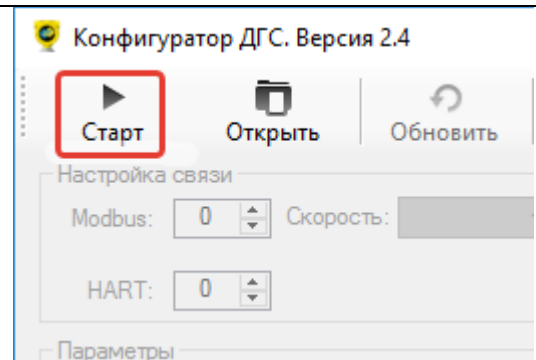

④ Click "Calibration" button

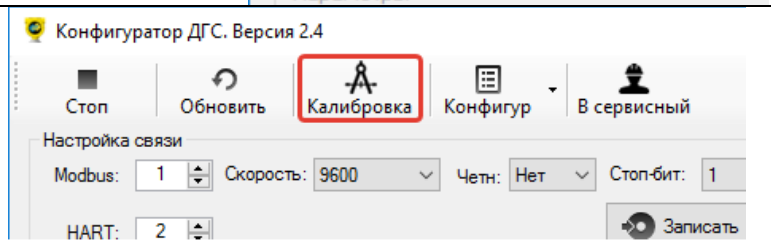

⑤ Calibration window appears.

Click "Zero calibration" button

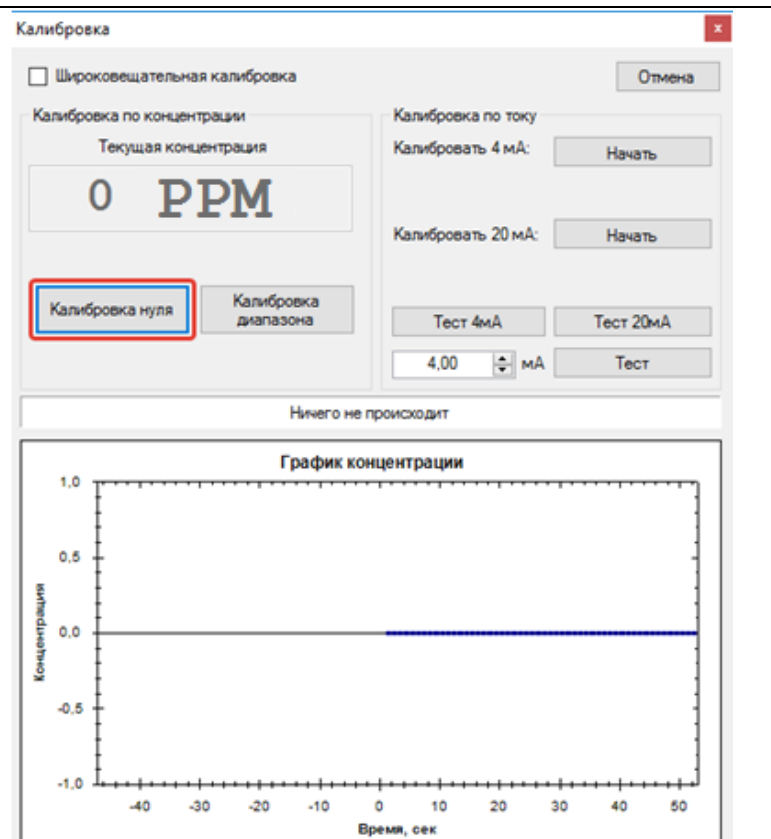

⑥ Ensure that the gas detector is calibrated in the area without any residual amounts of the measured gas. Otherwise supply zero gas to gas detector DGS ERIS-230. Click "Zero calibration" button.

Калибровка

Широковещательная калибровка Отмена

Калибровка по концентрации

Текущая концентрация

5 PPM

Калибровать ноль!

Калибровка по току

Калибровать 4 мА: Начать

Калибровать 20 мА: Начать

Тест 4мА Тест 20мА

4,00 мА Тест

Ожидание подтверждения от пользователя

График концентрации

Концентрация

Время, сек

⑦ Wait till the following message will appear: "Calibration is complete". If zero gas is used to set zero, turn off zero gas supply.

Калибровка

Широковещательная калибровка Отмена

Калибровка по концентрации

Текущая концентрация

0 PPM

Калибровать ноль! Калибровка диапазона

Калибровка по току

Калибровать 4 мА: Начать

Калибровать 20 мА: Начать

Тест 4мА Тест 20мА

4,00 мА Тест

Калибровка завершена

График концентрации

Концентрация

Время, сек

16.8 Span calibration using PC with installed software*



*Please refer to www.eriskip.com. for free software and software manual.

① Span calibration requires the following equipment:

- 1 – gas detector DGS ERIS-230;
- 2 – calibration cap;
- 3 – RS485/USB transmitter;
- 4 – PC with installed software;
- 5 – variable area flow meter;
- 6 – pressure regulator;
- 7 – state standard sample of calibration gas mixture
- 8 – power supply source.

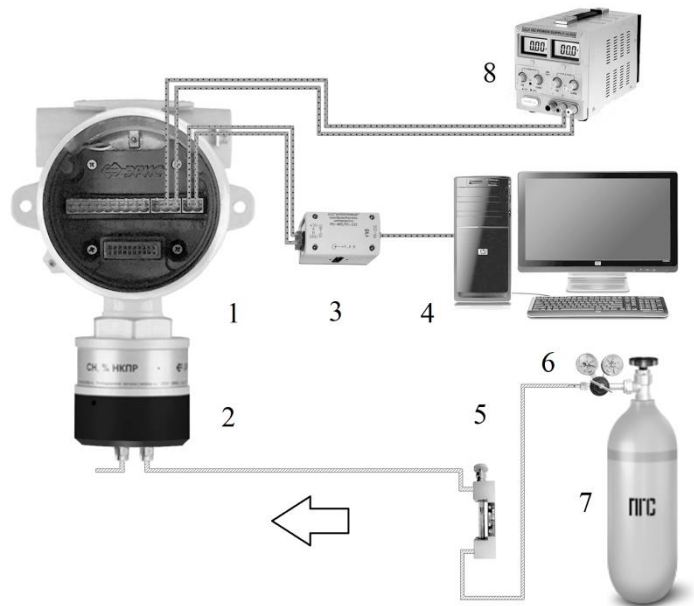

② Open the program, set the connection:

Select the gas detector connection port

Enter the device address in MODBUS line. The device address is two last digits of the serial number.

Example: Port: COM15.

Serial No. ER000000011

Modbus:11

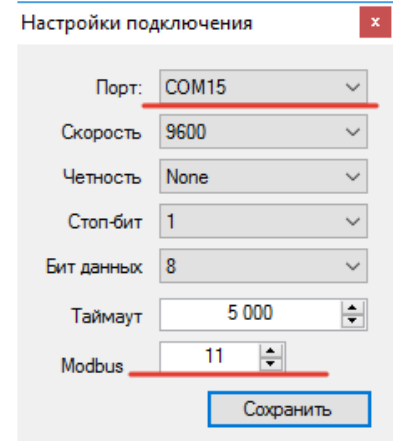

③ Click "Start" button

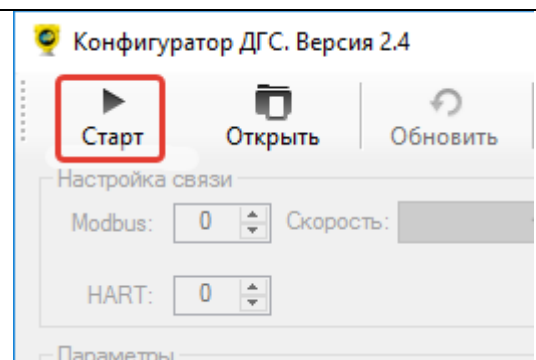

④ Click "Calibration" button

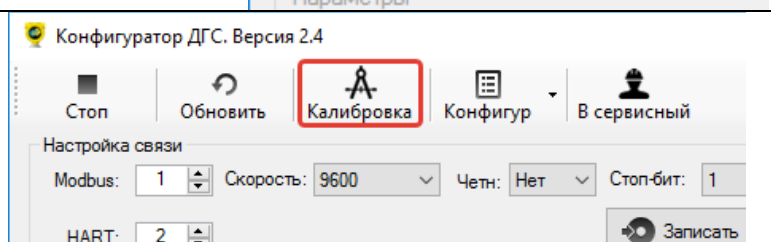

5 Calibration window appears.

Click "Span calibration" button

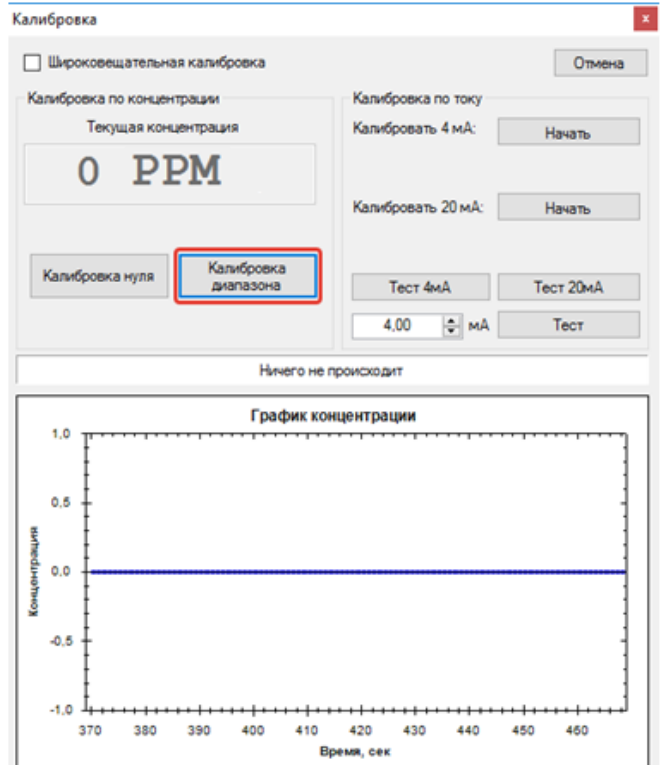

6 Enter the supplied gas concentration into the "Span calibration" input box.

Supply state standard sample of the calibration gas mixture using the calibration cap (the concentration shall be 25–75% of measurement range).

Click "Span calibration" button.

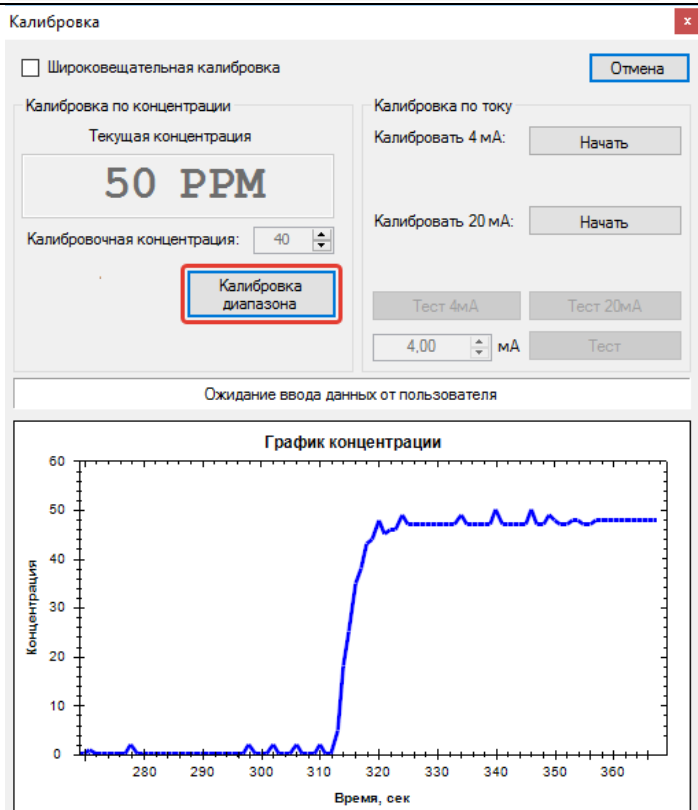

⑦ Wait till the following message will appear: "Calibration is complete".

The value in the "Current concentration" window shall correspond to the concentration of applied state standard sample of the calibration gas mixture.

Turn off the gas supply.

Span calibration is completed.

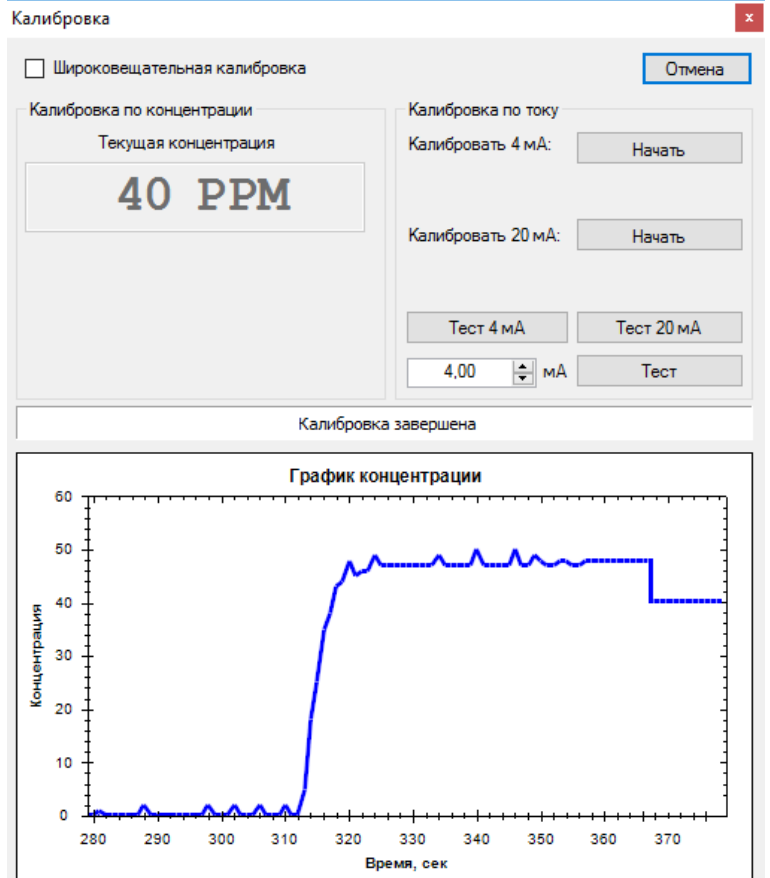

17 Possible faults

OLED display indicates the possible gas detector faults as error codes.

Displayed error code		Error description	Troubleshooting
DGS ERIS-230-1	DGS ERIS-230-3		
System errors			
Er12	Error code 12	Crystal oscillator (12 MHz) fault	Send gas detector to the manufacturer for repair
Er20	Error code 20	Inner heater fault	
Er21	Error code 21	Sensor heater fault	
Er25	Error code 25	EEPROM AT25 fault	
Er32	Error code 32	Low voltage in circuit of 3.3 V	
Er34	Error code 34	High voltage in circuit of 3.3 V	
Er45	Error code 45	FLASH AT25 fault	
Er49	Error code 49	Low voltage in circuit of 5.0 V	
Er51	Error code 51	High voltage in circuit of 5.0 V	
Er54	Error code 54	ADC AD5410 (current output) fault	
Er75	Error code 75	STLM75 temperature sensor fault	
-NO-	OPEN SENSOR	Sensor is absent	Install properly functioning sensor
Sensor faults			
SE11	Error code 11	ADS1113 fault	Install properly functioning sensor*
SE25	Error code 25	EEPROM AT25 fault	
SE30	Error code 30	Bridge voltage of 3.0 V is not within tolerance	
SE33	Error code 33	Voltage of 3.3 V is not within tolerance	
SE50	Error code 50	Voltage of 5.0 V is not within tolerance	
SE75	Error code 75	STLM75 fault	
SE91	Error code 91	LMP91000 fault	
Note-*			

18 Maintenance



Only trained personnel could have access to the internal parts of the gas detector for any kind of works.

The gas detector shall be operated only by personnel acquainted with the present operation manual and having completed the safety training.

Do not operate the gas detector with mechanical damages of the housing or damaged seal.

Do not open the gas detector in an explosion hazard area when power supply is on.

The gas detector housing shall be grounded. Internal and external grounding devices and earth signs according to GOST 21130-75 are envisaged for gas detector ground connection.

Repair of the gas detector shall be carried out by the manufacturer personnel or persons authorised by the manufacturer for repair works performance.

Do not disassemble sensors and interchange sensors parts.

Avoid influence of temperatures out of the specified operation range on the gas detector.

Upon service life expiration the replaceable electrochemical oxygen and toxic gases sensors shall be environment-friendly disposed. Disposal shall be carried out in accordance with the local regulations on waste management and legislation on environmental protection.

Do not burn electrochemical sensors, since the sensor cells may form toxic gases during combustion.

18.1 General guidelines

The maintenance shall be performed to ensure the smooth operation of the gas detector during the service life.



The maintenance shall be performed only by personnel acquainted with the safety rules for power system operation in the explosion hazard areas, acquainted with the present Operation Manual, certified and authorized to operate such devices.

Maintenance types and schedule:

- visual inspection of gas detector: once per six months;
- periodic operability check: once per six months;
- cleaning of gas detector sintered metal filter: once per year;
- sensor replacement: as may be required;
- verification: once per year (for DGS ERIS-230CT, DGS ERIS-230EC) or once per three years (for DGS ERIS-230IR).

Gas detector visual inspection and periodic operability check shall be performed at operation site. Cleaning of the sintered metal filter and sensor replacement shall be performed in the explosive safe area (the gas detector may be switched on). Verification shall be performed in a laboratory environment.

18.2 Visual inspection

Check the gas detector for mechanical damages and contaminants that could influence the gas detector operability. Use wet cloth and soap to remove contaminants if required.

18.3 Periodic operability check

Zero and span readings of the gas detector shall be periodically checked.

To check the operability, supply zero gas (zero grade air or nitrogen of high purity) and the calibration gas mixture using the calibration cap, the concentration of detected gas shall be 25–75% of measurement range. If the calibration gas mixture containing detected gas is not produced in pressure cylinder, then it is possible to apply equivalent calibration mixture (equivalent gas) with the corresponding correction factor. The actual value of equivalent gas concentration C , that corresponds to detected gas value, shall be calculated by formula:

$$C = C_1 \times K,$$

where C_1 – concentration value of equivalent gas,
 K – correction factor.

Equivalent gas and correction factor are specified in the gas detector datasheet.

Example: The gas detector is configured to measure diesel fuel. Equivalent gas: propane. Correction factor: 3.18. When propane gas mixture of 25% LFL is supplied, the diesel fuel concentration amounts to $25 \times 3.18 = 79.5\%$ LFL.

The gas detector readings shall be checked using the current loop (4–20) mA in accordance with Section 22. If the readings fall outside the permissible tolerance, perform zero and span calibration in accordance with Section 16.

18.4 Cleaning of sintered metal filter (for gas detector DGS ERIS-230IR)

The cleaning allows to recover filter capacity. Remove the moisture protection cap from the measurement module, unscrew the sensor protective cover (Fig. 26) and blow out the filter mounted in the cover by the compressed air from both sides starting from the inner side. If after the blowing visible contaminants still remain and clog the filter pores, replace the filter. To do so, replace the sensor cover as the filter is an integral part of it.

To order the spare part (sensor cover with sintered metal filter), contact the manufacturing company.

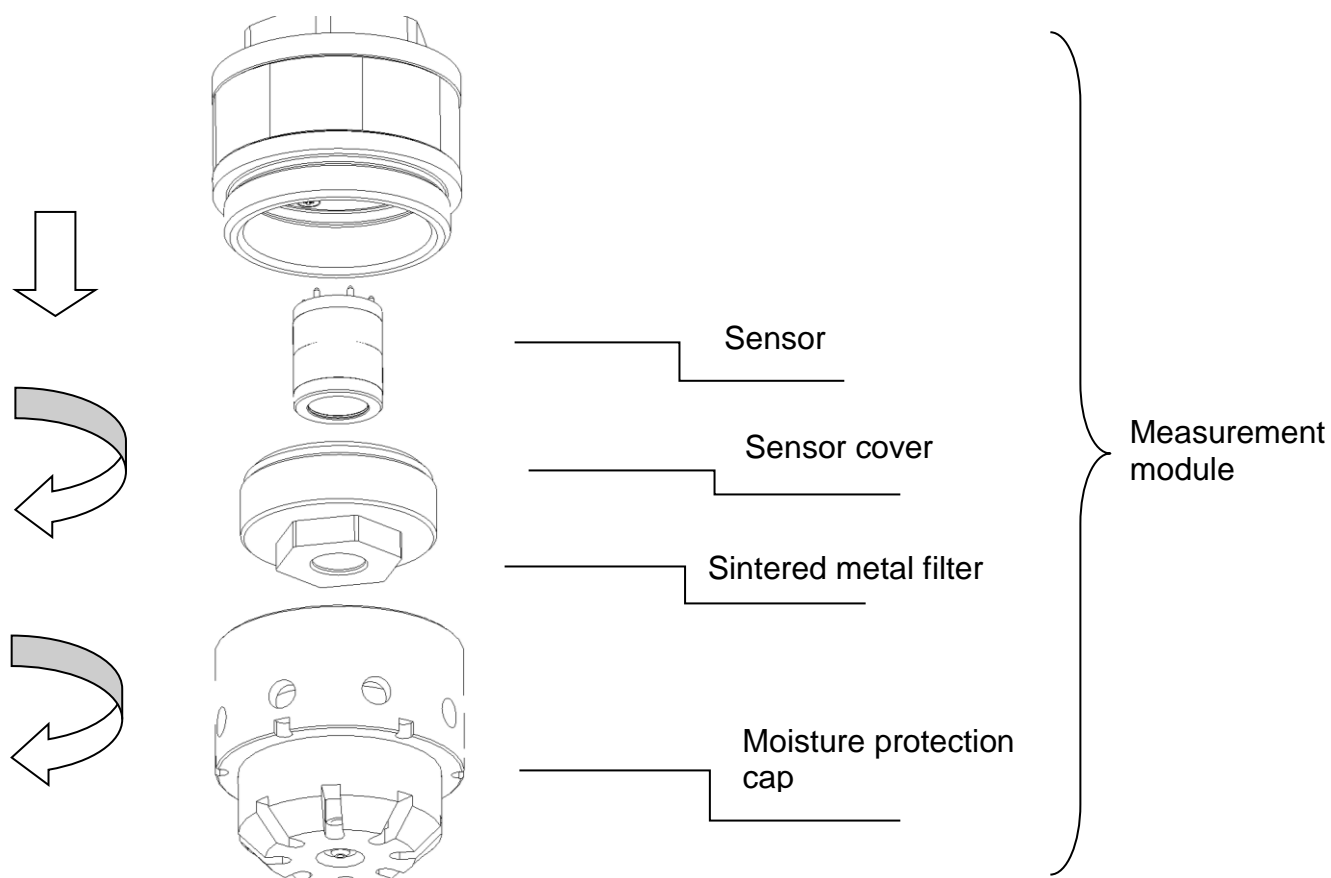

Figure 26- Measurement module disassembling diagram

18.5 Sensor replacement

The sensor shall be replaced if the gas detector readings fall outside the permissible tolerance and the calibration is impossible, or when the sensor got out of order.

The following actions shall be performed for sensor replacement (Fig. 26):

- switch off the gas detector power supply,
- remove the moisture protection cap of the measurement module,
- unscrew the sensor protective cover,
- pull the sensor with care and remove it from the socket,
- install the new sensor into the socket,
- assemble the measurement module in the reverse order.

To order the spare part (sensor), contact the manufacturing company.



After sensor replacement, the primary verification of the gas detector shall be performed in compliance with verification method MP 116-221-2014 with amendment No. 1.

18.6 Verification

The primary verification shall be performed before the gas detector is put in operation and after the repair, and periodic verification shall be performed during the operation life. Verification shall be performed as following: once per year (for DGS ERIS-230CT, DGS ERIS-230EC) or once per three years (for DGS ERIS-230IR). Verification shall be carried out in compliance with verification method MP 116-221-2014 with amendment No. 1.

19 Description and application of the audible and visible alarm

19.1 Description of the audible and visible alarm

The audible and visible alarm (hereinafter referred to as the alarm) is an optional accessory and is supplied under the special order.

The alarm is intended to give visible and audible signals in the explosion hazard areas in order to attract people attention in the event of danger or emergency situations.

Technical specifications:

- The alarm has 1ExdmIICT6X explosion proof marking.
- The alarm is designed for installation in the explosion hazard areas of 1st and 2nd classes according to GOST R 51330.9-99.
- The maximum level of sound pressure is minimum 110 dB at distance of 30 cm and under normal conditions;
- Ambient temperature range permissible for operation is from –60 up to +60°C;
- Ingress protection rating of IP67;
- Electric shock protection of III class;
- Overall dimensions are maximum 116×46×85 mm excluding cable dimensions;
- Maximum mass is 0.35 kg;
- Average service life is minimum 10 years;
- The alarm operation statuses are described in Table 7.

19.2 Application of the audible and visible alarm

The warranty period shall comprise 12 months from the date of the alarm commissioning, but not more than 18 months starting from the date of manufacture.

The alarm repairing shall be performed only at the manufacturing company.



Do not open and disassemble the alarm.

Do not use the alarm with the damaged housing parts and seals.

The external view of gas detector DGS ERIS-230 with the audible and visible alarm is shown in Figure 27.

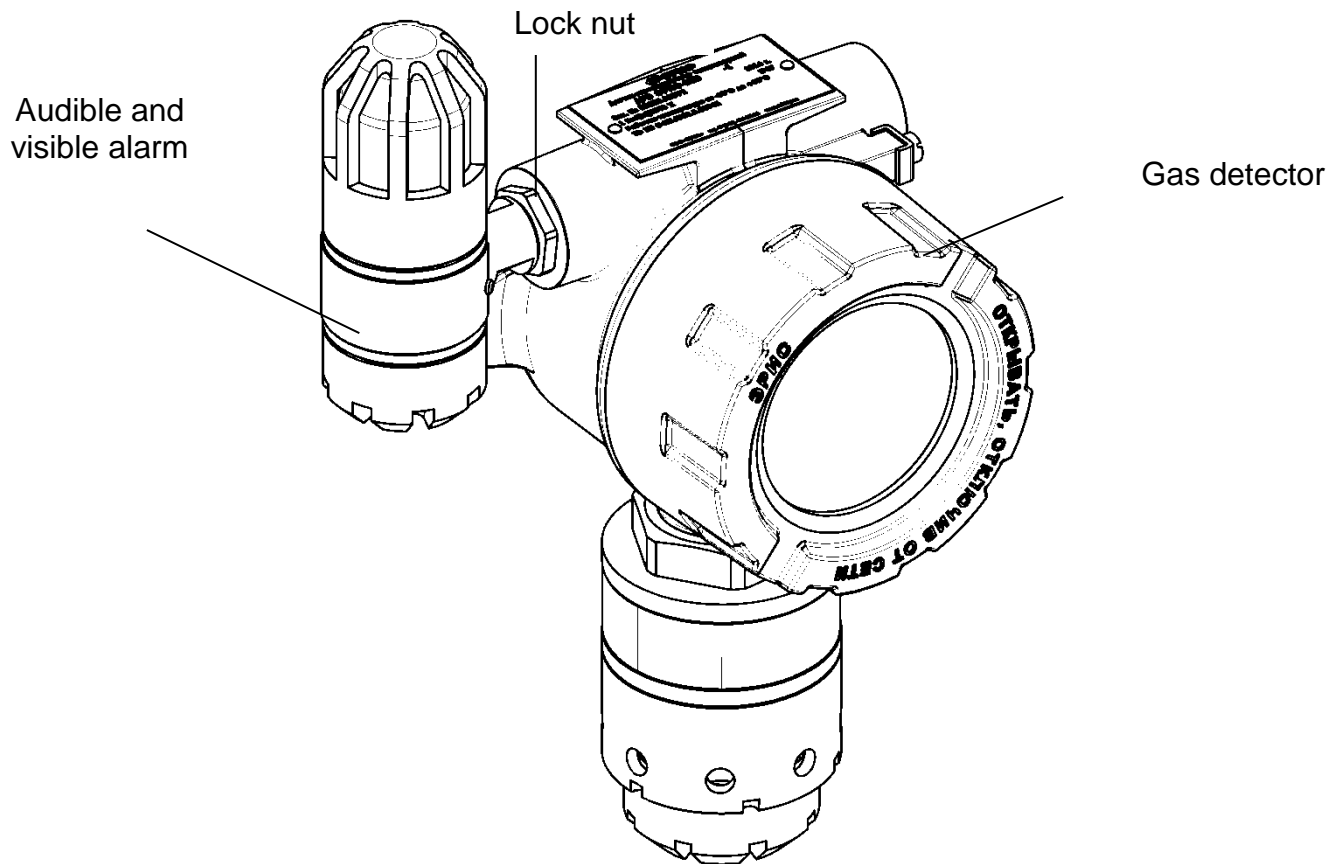

Figure 27. The external view of the gas detector with the audible and visible alarm

19.3 Operation of the audible and visible alarm



To disable the audible warning, attach the magnetic wand supplied along with the gas detector, to the marked section of the audible and visible alarm ✓, as shown in Figure 28.

To restart the visible and audible alarm, attach and hold the magnetic wand within 30 seconds. The alarm will be switched off with the intermittent beeping.

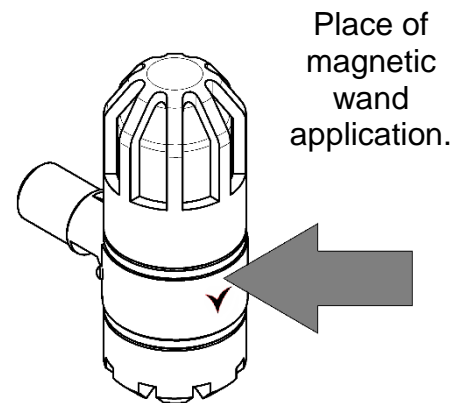

Figure 28-Place of magnetic wand application

The alarm operation statuses are described in Table 7.

Table 7. The alarm operation statuses

Process, mode		Visible alarm	Audible alarm
Pre-starting procedure	Audible and visible alarm actuation	LEDs glow green around a circle LEDs alternatively blink all colours (white, green, blue, red, yellow, violet)	2 short beeps
	DGS ERIS-230 search	LEDs blink blue on each side around a circle	-
	Audible and visible alarm initialisation	LEDs blink white once per second	-
Standard indication	Operation mode DGS ERIS-230 and audible and visible alarm are functioning properly	LEDs blink green once per second	-
	Configuration mode	LEDs blink white once per second	-
	Magnetic wand is attached	LEDs glow violet	Intermittent beep
Warnings	Maximum volume concentration of detected gas exceeds the set limit of ALARM 1	LEDs blink red one time, once per second	Continuous beep (siren)
	Maximum volume concentration of detected gas exceeds set limit of ALARM 2	LEDs blink red two times, once per second	Continuous beep (siren)
	DGS ERIS-230 measurement range is exceeded	Central LEDs glow yellow LEDs slowly blink red once per second	Continuous beep (siren)
Failures	DGS ERIS-230 fault	Central LEDs glow yellow LEDs slowly blink red once per second	Intermittent beep
	No communication with the sensor / sensor is damaged	Central LEDs glow yellow LEDs shortly blink red three times, once per second	Intermittent beep
	No communication with DGS ERIS-230 via MODBUS	LEDs blink yellow two times, once per second	Intermittent beep

19.4 Marking

The marking of the audible and visible alarm corresponds to the manufacturer drawings and includes the following:

- "Audible and visible alarm" indication
- manufacturer name and trade mark

- serial number of the audible and visible alarm in compliance with the manufacturer numbering system
- 1ExdmIICT6X explosion proof marking
- year of manufacture
- explosion safety sign in accordance with CU TR 012/2011
- conformity certificate No. CU TR 012/2011
- sign  of magnet application area.

19.5 Maintenance of audible and visible alarm

The maintenance of the audible and visible alarm shall include visual inspection and periodic operability check.

The maintenance shall include the visual inspection of the following:

- integrity of alarm housing and inlet fitting;
- secure fixation of alarm;
- integrity of seals;
- presence of explosion-proof marking.

Visual inspection shall be performed once per six months. The visual inspection of the alarm shall be performed simultaneously with gas detector DGS ERIS-230.

Besides, the alarm operability shall be checked once per six months simultaneously with DGS ERIS-230 operability check and shall include testing of audible and visible alarm signals.

20 HART menu

WELCOME SCREEN	
Menu item	Example
1 Device Setup	
2 Gas Concentration	0% LEL
4 PV Loop current	4 mA
5 Current Gas	Methane
7 Loop Current Mode	Point to Point HART Mode

Select Device Setup, then the following menu items appear:

Menu has the following structure:

DEVICE SETTING MENU	
Menu item	Submenu
1 Calibrate current output	1 Calibration of current output 2 Test current output
2 Calibrate sensor	Zero calibration Span calibration
3 Parameters	1 HART address 2 Alarm 1 3 Type of Alarm 1 4 Alarm 2 5 Type of Alarm 2 6 Hysteresis 1 7 Hysteresis 2 8 Measurement range

HART menu structure:

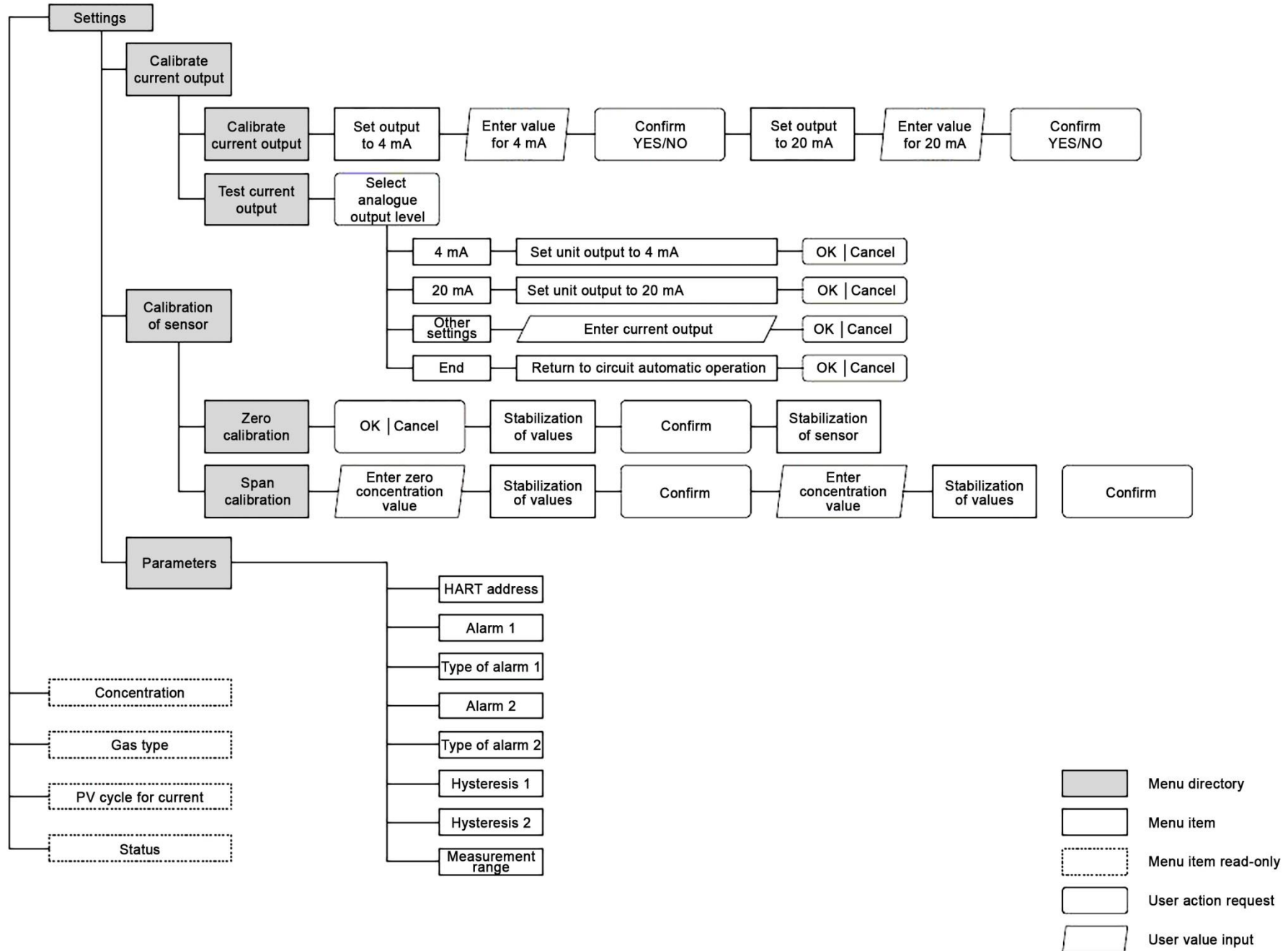

21 RS485 communication protocol

Interface: RS485 (default settings: 9600 bit/s, 8 databits, Nonparity, stop-bit 1; Modbus device address is the last two digits of the serial number).

Holding registers:

0x03 – read holding registers

0x06 – write single register

0x10 – write multiple registers

Address	Description	Range	Access
0x0000	Module ID	230	R/-
0x0001	RS485 speed and network address upper byte - RS485 network address: 1–255 lower byte: Bits 0–3 – Rate: -- 0 – 1200 baud -- 1 – 2400 baud -- 2 – 4800 baud -- 3 – 9600 baud -- 4 – 19200 baud -- 5 – 38400 baud -- 6 – 57600 baud -- 7 – 115200 baud Bits 4, 5 – Parity: -- 0 – no -- 1 – odd -- 2 – even Bit 6 – Stop-bits: -- 0 – 1 stop-bit -- 1 – 2 stop-bits		R/W
0x0002	HART <u>network address</u>	1–15	R/W
0x0003	Status: bit 0 – always 0 bit 1 – alarm 1 bit 2 – alarm 2 bit 3 – sensor is missing or damaged bit 4 – maintenance mode bit 5 – signal excess bit 6 – module initialization is in progress bit 7 – mode 0 – operation, 1 – configuration bit 8 – reserve bit 9 – no communication with the gas detector bit 10 – fault (potential problem with the gas detector) bit 11 – reserve		R/W

	bit 12 – reserve bit 13 – DAC. No communication bit 14 – DAC. The current is not set. Possible open circuit fault bit 15 - presence of magnet		
0x0004	Module settings: - bit 4–7 – Measuring unit -- 0 – % vol. -- 1 – ppm -- 2 – ppb -- 3 – % LFL -- 4 – g/cm ³ -- 5 – mg/m ³ -- 9 – mg/m ³ - bit 8–9 – Discreteness: -- 0 - *1; -- 1 - *10; -- 2 - *100; - bit 10–15 – Reserve:		R/W
0x0005	Lower range value	0–65535	R/W
0x0006	Upper range value: measurable	0–65535	R/W
0x0007	Alarm 1	0–65535	R/W
0x0008	Alarm 2	0–65535	R/W
0x0009	Hysteresises - bit 0–7 – Hysteresis 1 - bit 8–15 – Hysteresis 2		R/W
0x000A	Delays of alarm response - bit 0–7 – Delay of alarm 1 response (seconds) - bit 8–15 – Delay of alarm 2 response (seconds)		R/W
0x000B	<u>Time of automatic alarm reset</u>		R/W
0x000C	Calibration mode <i>Read:</i> 0 – operation mode 1 – zero calibration 2 – span calibration 3 – 4 mA point calibration 4 – 20 mA point calibration 5 – current output testing 6 – change of sensor parameters <i>Write:</i> 0x0000 – operation mode activation 0x185D – Mode. Zero calibration 0x64C4 – Mode. Span calibration 0x5530 – Mode. Calibration of 4 mA point		R/W

	0x55C3 – Mode. Calibration of 20 mA point 0x3535 – Mode. Current output testing 0x7294 – changes saving		
0x000D	<u>Span gas concentration</u>		R/W
0x000E	<u>Concentration during calibration using magnetic wand</u>		R/W
0x000F	Current for initialization mode, * 100, mA		R/W
0x0010	Current for maintenance mode, * 100, mA		R/W
0x0011	Current for calibration mode, * 100, mA		R/W
0x0012	Dead band		R/W
...			
0x001B	SENSOR. Sensor type		R/-
...			
0x0020	SENSOR. Gas name. Symbol 0 and 1		R/-
0x0021	SENSOR. Gas name. Symbol 2 and 3		R/-
0x0022	SENSOR. Gas name. Symbol 4 and 5		R/-
0x0023	SENSOR. Gas name. Symbol 6 and 7		R/-
0x0024	SENSOR. Gas name. Symbol 8 and 9		R/-
0x0025	SENSOR. Gas name. Symbol 10 and 11		R/-
0x0026	SENSOR. Gas name. Symbol 12 and 13		R/-
0x0027	SENSOR. Gas name. Symbol 14 and 15		R/-
...			
0x0071	Point of range reference to 20 mA Lo		R/W
0x0072	Point of range reference to 20 mA Hi		R/W
0x0073	Upper value: measured in mg/m ³ Lo		R/W
0x0074	Upper value: measured in mg/m ³ Hi		R/W
0x0075	Displayed and applied concentration		R/W
...			
0x0078	SENSOR. Low value		R/-
0x0079	SENSOR. Upper value: displayed		R/-
0x007A	SENSOR. Upper value: measurable		R/-
0x007B	SENSOR Measurement unit and discreteness		R/-

INPUT registers

0x04 – read input registers

Address	Description	Range	Access
0x0100	Module ID	230	R/-
0x0101	Serial number. Hi		R/-
0x0102	Serial number. Lo		R/-
0x0103	Software build		R/-
0x0104	Software build		R/-
0x0105	DGS output current * 100		R/-
0x0106	State Lo: bit 0 – always 0 bit 1 – alarm 1 bit 2 – alarm 2 bit 3 – sensor is missing or damaged bit 4 – maintenance mode bit 5 – signal excess bit 6 – module initialization is in progress bit 7 – mode 0 – operation, 1 – configuration bit 8 – reserve bit 9 – no communication with the sensor bit 10 – fault (potential problem with the sensor) bit 11 – reserve bit 12 – reserve bit 13 – DAC. No communication bit 14 – DAC. The current is not set. Possible open circuit fault bit 15 – presence of magnet		R/-
0x0107	State Hi: bit 0 – AT25. Memory faults bit 1 – Current output. Very low resistance, probable short circuit bit 2 – Current output. Very high resistance, probable open circuit fault or long-distance line bit 3 – AT45. Memory faults		R/-
0x0108	Temperature.* 10		R/-
0x0109	SENSOR Temperature.* 10		R/-
0x010A	SENSOR. Type		R/-
0x010B	SENSOR. Concentration * multiplier		R/-
0x010C	SENSOR. Status Sensor status back-up register		R/-
0x010D	SENSOR. Software build		R/-

0x010E	SENSOR. Software build		R/-
0x010F	SENSOR. Communication quality, %		R/-
...			
0x0160	Concentration, mg/m ³ Lo		R/-
0x0161	Molar mass of gas * 100		R/-
0x0162	Concentration, mg/m ³ Hi		R/-
0x0166	Current concentration. Lo		R/-
0x0167	Current concentration. Hi		R/-

The present clause contains only the key registers. The complete communication protocol is available on request.

22 Nominal static conversion function

The concentration value delivered through the current loop is calculated by the nominal static conversion function. The formula shows the relationship between current loop output signal and detected gas concentration:

$$I_{nom} = 16 \cdot \frac{C_i}{C_{max}} + 4, \quad (1)$$

where I_{nom} – current output, mA;

C_i – measured concentration, % vol.;

C_{max} – maximum volume concentration of detected gas that corresponds to current output signal of 20 mA.

The measured concentration is calculated by the following formula:

$$C = \frac{|I_i - I_0|}{K}, \quad (2)$$

where I_i – gas detector current output at the control point (mA);

I_0 – gas detector initial current output of 4 mA;

K – conversion coefficient:

$$K = \frac{16 \text{ mA}}{C_{max} - C_{min}}, \quad (3)$$

where C_{max} – maximum concentration of measurement range;

$C_{min} = 0$ – minimal concentration of measurement range.

Annex A

Gases detected by flammable gas sensors (IR/CT)

1. Amylene (isomers, pentenes)
2. Acetylene
3. Acetone
4. Acetaldehyde
5. Diesel fuel according to GOST 305-2013
6. White spirit according to GOST 3134-78
7. Jet fuel according to GOST 10227-86
8. Motor petrol
9. Aviation petrol B-70
10. Rubber solvent petrol
11. Aviation petrol according to GOST 1012-2013
12. Natural-gas condensate
13. Hexane
14. Heptane
15. Unleaded petrol according to GOST 51866-2002
16. Kerosene according to TU 38 71-5810-90
17. Benzene
18. Butane
19. 1,3-butadiene
20. Butylene (isomers)
21. Butanol
22. Hydrogen
23. Water gas
24. Vinyl chloride**
25. Liquefied petroleum gases according to GOST 27578-87
26. Compressed natural fuel gas according to GOST 27577-2000*
27. Divinyl
28. Dioxane
29. Dichloroethane**
30. Diethyl ether
31. Isobutane
32. Isobutanol
33. Isobutylene
34. Isopentane
35. Isopropanol
36. Isoprene
37. Coke gas

38. Xylol
39. 2-methyl-2-propanol
40. Methanol
41. Methane
42. Methyl ethyl ketone, ethyl methyl ketone
43. Propylene oxide
44. Carbon monoxide
45. Acrylonitrile
46. Acetonitrile
47. Carbon dioxide
48. Ethylene oxide
49. Octane
50. Vapours of petroleum and petroleum products
51. Pentane
52. Petroleum ether
53. Associated petroleum gas*
54. Propylene
55. Propyl alcohol
56. Propane
57. Turpentine
58. Styrene
59. Toluene
60. Acetic acid
61. Acetic acid methyl ester, methyl acetate
62. Acetic acid ethyl ester, ethyl acetate
63. Acetic acid butyl ester, butyl acetate
64. Cyclohexane
65. Ethane
66. Ethylene
67. Ethylbenzene
68. Ethanol
69. Formaldehyde



* *Controlled substance contains catalyst poisons and/or aggressive substances.*

***Controlled substance is catalyst poison and/or aggressive substance.*



Promyshlennaya street 8/25
Chaikovsky, Perm region 617760
Russia

phone: 8 (34241) 6-55-11
e-mail: info@eriskip.ru
eriskip.com